

Introductory Physics Volume Two

Saint Mary's College
Chris Ray
Spring 2012

cover art by Susana del Baño Ranner

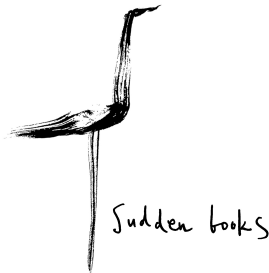

Contents

1	Electric Field	
1	Electric Charge	5
2	Coulomb's Law	9
3	Electric Field	13
4	Vector and Scalar Fields	18
5	Continuous Charge Distributions	18
6	Gauss's Law	21
7	More Examples	25
8	Homework	34
9	Summary	37
2	Electric Potential	
1	Electric Potential	39
2	Equipotentials	43
3	Conductors in Equilibrium	45
4	Capacitors	46
5	Energy in an Electric Field	49
6	Electric Potential of a Point Charge	50
7	More Examples	51
8	Homework	55
9	Summary	58
3	Circuits	
1	Introduction	59
2	Electric Current	59
3	Ohm's Law	60
4	Electric Power	62
5	Kirchhoff's Rules	63
6	Resistors in Combination	64
7	Capacitors in Combination	66
8	Capacitor Circuits	67
9	More Examples	69
10	Homework	76
11	Summary	81
4	Magnetic Fields	
1	Magnetic Field	83
2	Magnetic Force on a Current	83
3	Trajectories Under Magnetic Forces	85
4	Lorentz Force	87
5	Hall Effect	88

6	More Examples	90
7	Homework	95
8	Summary	98
5	Sources of Magnetic Field	
1	Sources of Magnetic Field	99
2	Ampere's Law	103
3	Force Between Parallel Wires	107
4	More Examples	107
5	Homework	113
6	Summary	116
6	Time Varying Fields	
1	Introduction	117
2	Faraday's Law	117
3	Maxwell's Extension of Ampere's Law	121
4	Inductance	122
5	Alternating Current	124
6	AC Power and RMS Voltage	124
7	AC Circuit Elements	125
8	Phasor Diagrams	127
9	Homework	131
10	Summary	137
7	Wave Optics	
1	Maxwell Equations	139
2	Describing Oscillations	141
3	Describing Waves	143
4	Electromagnetic Waves	146
5	Interference of Waves	148
6	Interferometer	150
7	Interference of Two Sources	151
8	Far Field Approximation	152
9	Thin Film Interference	154
10	Single Slit Diffraction	156
11	Homework	157
12	Summary	161
8	Geometric Optics	
1	Short Wavelength Limit	163
2	Reflection	164
3	Virtual Image	164
4	Snell's Law	165
5	Virtual Image Caused by Refraction	166
6	Thin Lens Equation	168
7	Virtual Image in a Converging Lens	171

8	Diverging Lenses	173
9	Sign Conventions and Coordinates System	174
10	Multi-Lens Optical Systems	175
11	Homework	177
12	Summary	179
A	Hints	
B	Index	
C	Useful Mathematics	
1	Trigonometry	192
2	Fundamental Derivatives and Integrals	192
3	Power Series Expansions	193
D	Physical Constants and Data	
1	Astronomical Data	194
2	Index of Refraction	194
3	Approximate Electrical Conductivity	194
4	Fundamental Constants	196
5	Unit Conversions	196
6	Unit Prefixes	196

1

Electric Field

§ 1.1 Electric Charge

Sometimes when you pet a cat, the cat's fur begins to stand up on end and if you then touch the cat's nose, you and the cat are both shocked. Through petting, the cat has been charged with static electricity. The shock occurs when the cat discharges the built up static charge to your finger. She has not done this on purpose, it is simply the inevitable force of nature taking its course, so don't get mad at the cat. Of course if you had not touched the cat's nose she would have lost her charge more gradually through the air, so she might have reason to be mad at you for sucking all the charge from her nose.

Let's investigate static electricity further.

DEMO

Static Electricity: Rub a rubber rod with fur and hang it by a string. Rub a second rubber rod with fur and bring it near the first:

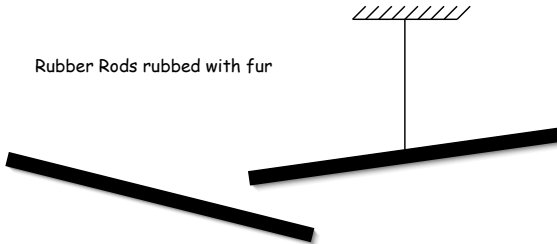

Observe that the charge rods repel one another. Thus, for two rods of the same material rubbed in the same way we find there will be a repulsive force between them. Remove the second rubber rod, and replace it with a plexiglass rod that has been rubbed with the fur. Observe that the hanging rubber rod is attracted to the plexiglass rod. So it is possible by rubbing different objects with fur to cause either attractive or repulsive forces between the objects.

The observations above can be explained by the existence of two types of “electric charge.” Objects with the same charge repel each other, while objects with different charges attract one another. The two types of charge, following the convention of Benjamin Franklin, are called positive and negative. Rubbing rubber with fur leaves the rubber with a negative charge, while rubbing plexiglass with fur leaves the plexiglass with a positive charge.

Fact: Two Types of Charge

From observations, such as the demonstration with the rubber rods and fur, we have the following rules:

- There are two types of electric charge: + and -.
- Objects with the same sign charge repel.
- Object with oppositely signed charges attract

⊙ Do THIS NOW 1.1

Your friend Albert claims that he has isolated a third type of electric charge in nature. He calls the three types of charge A , B and C . Explain how he would prove this to you. Hint: you might think about the rock-paper-scissors game, and make a table showing which pairs are attractive and which are repulsive.

Does the fur rubbing against the rubber (plexiglass) create the negative (positive) electric charge? It turns out that the answer is no. Careful experiments show that whenever a negative electric charge shows up an equal amount of positive charge will be found somewhere else, and vice versa. The net charge in the universe remains zero. To see this for the rod-fur case, consider the following. Charge a rubber rod with fur, hang the rod and then bring the fur near the rod. The negatively charged rod will be attracted to the fur, showing that the fur has gained a positive charge. We can understand what is going on by considering the fundamental building blocks of normal matter: protons, neutrons and electrons. Protons have a positive charge $+e$, neutrons have no charge, and electrons have a negative charge $-e$. Uncharged objects contains an equal number of electrons and protons. A net electric charge is usually established on an object by adding or removing electrons. In the case of the fur and rod, electrons are removed form the fur and collected by the rod. This leaves the fur with a net positive charge (more protons than electrons) and the rod with a net negative charge (more electrons than protons).

⊙ Do THIS NOW 1.2

Explain why the cat's fur stands on end when it is pet.

Fact: Electric Charge

Electric Charge is neither created nor destroyed.

DEMO

Charging Without Rubbing: Hang two small metal balls as indicated below:

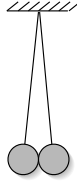

Then charge a rubber rod with fur, place it in contact with the metal balls, and then remove it. The two balls will be observed to repel each other.

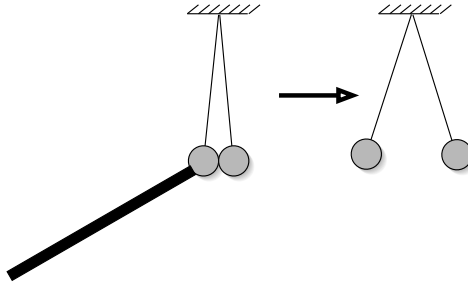

Here is how we can explain the demonstration. When the rubber rod comes in contact with the metal, some of the charge (which is negative since it is from a rubber rod rubbed with fur) moves over to the metal. This is because metals easily accept or give up electric charge; electric charge moves easily through metals. If we indicate the charges using negative signs, then we can represent what happens with the following picture:

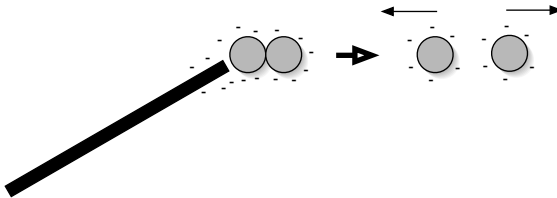

The charges move from the rubber rod onto the metal balls because of the repulsive forces between them. Once isolated, the two metal spheres repel each other because they both have a net charge of the same sign.

EXAMPLE Two equal masses, each with mass $m = 4\text{g}$, are electrically charged and hung using string as shown. If the masses hang in equilibrium at an angle $\theta = 10^\circ$, what is the magnitude of the electric force that each mass exerts on the other?

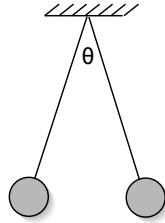

First draw a free body diagram for one of the masses:

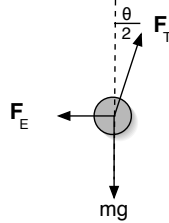

Sum forces:

$$\sum \vec{F} = \hat{i}(F_T \sin \frac{\theta}{2} - F_E) + \hat{j}(F_T \cos \frac{\theta}{2} - mg) = 0$$

This gives two equations:

$$F_E = F_T \sin \frac{\theta}{2}$$

$$F_T \cos \frac{\theta}{2} = mg$$

Solving for the electric force F_E gives

$$F_E = mg \tan \frac{\theta}{2} = (.004\text{kg})(9.8 \frac{\text{m}}{\text{s}^2}) \tan(5^\circ) = 3.4\text{mN}$$

DEMO

Moving Charges: Place an aluminum can on a table. Perviously we showed that we had two types or charge. If we produce either of these types of charge the can is attracted toward the charge.



How can we understand this apparently new type of charge, a charge that is attracted to both positive and negative charges? The place to start is consider the aluminum of which the can is composed. Each aluminum atom is composed of an equal number of protons and electrons, so the net charge of the can is zero. But there is a difference between the protons and electrons. The aluminum atoms are locked together in a crystal lattice, with the protons locked together with the neutrons in the nucleus of the atoms. The protons cannot move. On the other hand some of the electrons are shared between all of the atoms, and move around freely. This is what makes aluminum a *conductor*, it has electrons that move freely through the bulk of the material.

So when a positively charged rod is brought near the can the electrons are attracted toward the oppositely charged rod and they move within the metal a little bit toward the rod. This leaves the can with a net negative charge on the side toward the rod and a net positive charge on the side away from the rod. The net positive charge is because the protons did not move, so that when the electrons moved toward the other side of the can, the protons were left alone, unpaired.

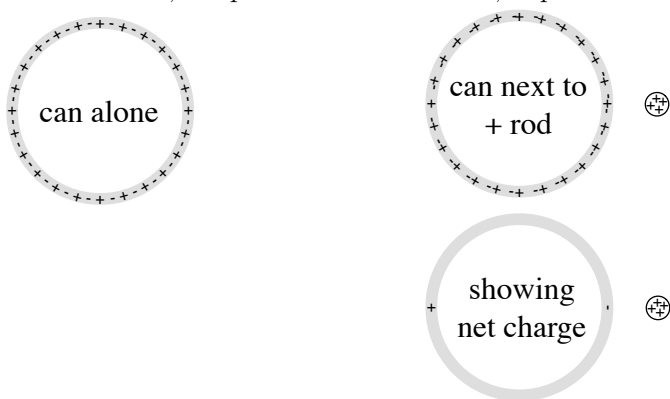

One might think that the net force would still be zero once the electrons have redistributed themselves, since we end up with a net positive charge on one side that is repelled and a net negative charge on the other side that is attracted. But it ends up that the force between two charges decreases with distance, so that the repulsive force is less than the attractive force.

⊙ Do THIS NOW 1.3

Explain how a negatively charged rod also attracts the can.

§ 1.2 Coulomb's Law

As we have seen there is a force between charged objects. After careful observation it was determined that the electrical force is

similar to the gravitational force. Recall that the gravitational force between two massive objects is inversely proportional to the square of the distance between the objects and proportional to the weight of each object. The electric force between two charged objects is also inversely proportional to the square of the distance between the objects and is proportional to the charge on each object. This observational fact is referred to as Coulomb's Law.

Fact: Coulomb's Law

The magnitude of the force between charges q_a and q_b that are a distance r apart is given by

$$F = \frac{q_a q_b}{4\pi\epsilon_0} \frac{1}{r^2}$$

where $\frac{1}{4\pi\epsilon_0} = 8.987552 \times 10^9 \text{ N} \cdot \text{m}^2/\text{C}^2 \approx 9.0 \times 10^9 \text{ N} \cdot \text{m}^2/\text{C}^2$.

It has already been noted that the direction of the electric force is determined by the sign of the charges: opposites charges attract, like charges repel.



Fact: Coulomb's Law in Vector Form

The magnitude and direction of the electric force can be combined into one vector expression of Coulomb's Law as follows:

$$\vec{F}_{ab} = \frac{q_a q_b}{4\pi\epsilon_0} \frac{\vec{r}_a - \vec{r}_b}{|\vec{r}_a - \vec{r}_b|^3}$$

where \vec{F}_{ab} is the force on charge a due to charge b and \vec{r}_a and \vec{r}_b are the position vectors of the two charges. Note that if we let $\vec{r} = \vec{r}_a - \vec{r}_b$ that we can write

$$\vec{F}_{ab} = \frac{q_a q_b}{4\pi\epsilon_0} \frac{1}{r^2} \hat{r}$$

The vectors in the above definition are pictured below.

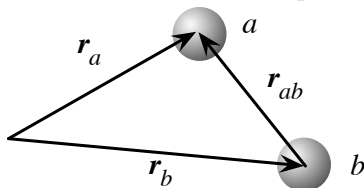

Both vectors are from the origin of the coordinate system, which can be chosen for computational convenience.

EXAMPLE

Consider three charges as shown. We want to know the net force on charge a due to charges b and c .

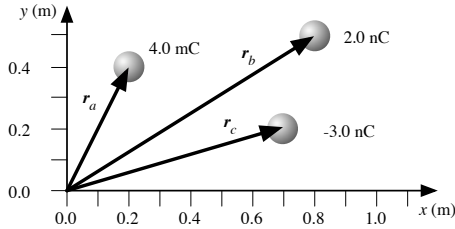

We find from the diagram that

$$\vec{r}_a = (0.2\hat{i} + 0.4\hat{j})\text{m} \quad \text{and} \quad q_a = 4.0 \times 10^{-3}\text{C}$$

$$\vec{r}_b = (0.8\hat{i} + 0.5\hat{j})\text{m} \quad \text{and} \quad q_b = 2.0 \times 10^{-9}\text{C}$$

$$\vec{r}_c = (0.7\hat{i} + 0.2\hat{j})\text{m} \quad \text{and} \quad q_c = -3.0 \times 10^{-9}\text{C}$$

so that we can compute

$$\vec{r}_a - \vec{r}_b = (-0.6\hat{i} - 0.1\hat{j})\text{m} \quad \text{and} \quad q_a q_b = 8.0 \times 10^{-12}\text{C}^2$$

$$\vec{r}_a - \vec{r}_c = (-0.5\hat{i} + 0.2\hat{j})\text{m} \quad \text{and} \quad q_a q_c = -12.0 \times 10^{-12}\text{C}^2$$

so that

$$\begin{aligned} \vec{F}_a &= \vec{F}_{ab} + \vec{F}_{ac} \\ &= \frac{q_a q_b}{4\pi\epsilon_0} \frac{\vec{r}_a - \vec{r}_b}{|\vec{r}_a - \vec{r}_b|^3} + \frac{q_a q_c}{4\pi\epsilon_0} \frac{\vec{r}_a - \vec{r}_c}{|\vec{r}_a - \vec{r}_c|^3} \\ &= 0.072\text{N} \frac{-0.6\hat{i} - 0.1\hat{j}}{|-0.6\hat{i} - 0.1\hat{j}|^3} - 0.108\text{N} \frac{-0.5\hat{i} + 0.2\hat{j}}{|-0.5\hat{i} + 0.2\hat{j}|^3} \\ &= 0.072\text{N} \frac{-0.6\hat{i} - 0.1\hat{j}}{(0.6^2 + 0.1^2)^{3/2}} - 0.108\text{N} \frac{-0.5\hat{i} + 0.2\hat{j}}{(0.5^2 + 0.2^2)^{3/2}} \\ &= 0.32\text{N}(-0.6\hat{i} - 0.1\hat{j}) - 0.69\text{N}(-0.5\hat{i} + 0.2\hat{j}) \\ &= (0.15\hat{i} - 0.17\hat{j})\text{N} \end{aligned}$$

The net force is to the right and down at about a 45° .

If we reworked the previous example but with the charge q_a doubled, then we would find that the force on the charge q_a would also be doubled, $\vec{F}_a = 2(0.15\hat{i} - 0.17\hat{j})\text{N}$. In general the force on a charge is proportional to the charge. For example, in the previous example

$$\vec{F}_a = q_a(37.5\hat{i} - 42.5\hat{j})\frac{\text{N}}{\text{C}}.$$

So we find that the ratio of the force and charge is a constant.

$$\frac{\vec{F}_a}{q_a} = (37.5\hat{i} - 42.5\hat{j})\frac{\text{N}}{\text{C}}.$$

This observation leads to the definition of the *electric field*, which occurs in the next section.

When computing the net electric force it is sometimes easier to deal with the directions “by hand”. If you can tell the direction of the force simply by looking at the configuration, then there is no reason to use the vector form of Coulomb’s law. In such a situation just use the magnitude form $F = \frac{q_a q_b}{4\pi\epsilon_0 r^2}$. The following example will demonstrate the “by hand” method.

EXAMPLE There are three equal charges q at each vertex of an equilateral triangle with sides of length L . What is the force on each charge?

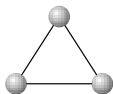

Let us find the force on the charge at the top. We know that the forces are repulsive so that we can draw the free body diagram for the charge on the top.



By inspection we see that the two forces are both at a 30° angle from the vertical, and that the horizontal components of the two forces are equal and opposite. So that when we add the two forces together, to get the net force, the horizontal components will cancel. The net force will be just the sum of the vertical components.

$$\begin{aligned}\vec{F}_{\text{net}} &= F_{1y}\hat{j} + F_{2y}\hat{j} = F_1 \cos 30^\circ\hat{j} + F_2 \cos 30^\circ\hat{j} \\ &= \frac{q^2}{4\pi\epsilon_0} \frac{1}{L^2} \cos 30^\circ\hat{j} + \frac{q^2}{4\pi\epsilon_0} \frac{1}{L^2} \cos 30^\circ\hat{j} \\ &= 2 \frac{q^2}{4\pi\epsilon_0} \frac{1}{L^2} \cos 30^\circ\hat{j}\end{aligned}$$

By the symmetry of the configuration the force on the other two charges will be the same magnitude and also pointing directly away from the center of the group.

▷ **PROBLEM 1.1**

There are two $+q$ charges and two $-q$ charges on the corners of a square of size a as shown.

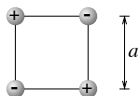

Compute the net force on each charge?

▷ PROBLEM 1.2

You have three charges as shown.

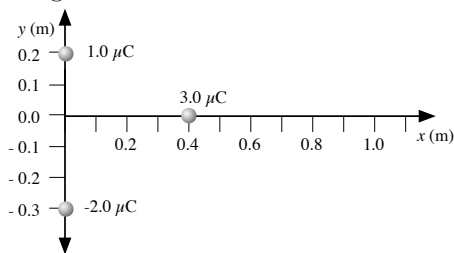

What is the net force on each charge?

§ 1.3 Electric Field

Definition: **Electric Field**

If a particle with charge q_a is placed at a point in space and F_a is the net electric force on this particle due to all other charges, then the *electric field* at that point in space is the ratio of the force on the particle and the charge of the particle.

$$\vec{E} = \frac{\vec{F}_a}{q_a}$$

You can think of the electric field as the force per charge in the same way that pressure is the force per area. It is important to understand the following points about the electric field:

- The electric field does not depend on the test charge q_a in any way.
- The electric field represents the effect of all the other charges.
- The electric field is different at each point in space.

We will now work a specific example in order to demonstrate these three properties of the electric field. It is important to follow the details of the computation in this example very closely since there is much to learn from it. Consider the configuration of two charges shown below.

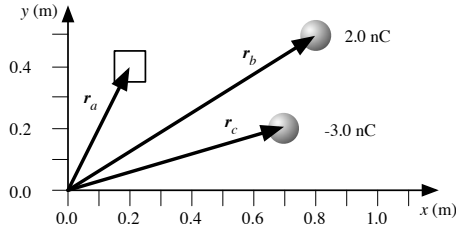

We calculated this configuration in a previous example where the test charge q_a was at the point $\vec{r}_a = (0.2\hat{i} + 0.4\hat{j})\text{m}$ and we found that the force at this point was

$$\vec{F}_a = q_a(37.5 \hat{i} - 42.5 \hat{j}) \frac{\text{N}}{\text{C}}$$

so that the electric field at this point is

$$\vec{E}(0.2\text{m}, 0.4\text{m}) = \frac{\vec{F}_a}{q_a} = (37.5 \hat{i} - 42.5 \hat{j}) \frac{\text{N}}{\text{C}}$$

We can find the electric field at other points \vec{r}_a as well.

$$\begin{aligned} \vec{E}(\vec{r}_a) &= \frac{\vec{F}_a}{q_a} = \frac{\vec{F}_{ab}}{q_a} + \frac{\vec{F}_{ac}}{q_a} \\ &= \frac{q_b}{4\pi\epsilon_0} \frac{\vec{r}_a - \vec{r}_b}{|\vec{r}_a - \vec{r}_b|^3} + \frac{q_c}{4\pi\epsilon_0} \frac{\vec{r}_a - \vec{r}_c}{|\vec{r}_a - \vec{r}_c|^3} \end{aligned}$$

We will stop at this point to notice that the charge q_a has already dropped out of the equation. So that we can write the electric field at an arbitrary location \vec{r} as

$$\vec{E}(\vec{r}) = \frac{q_b}{4\pi\epsilon_0} \frac{\vec{r} - \vec{r}_b}{|\vec{r} - \vec{r}_b|^3} + \frac{q_c}{4\pi\epsilon_0} \frac{\vec{r} - \vec{r}_c}{|\vec{r} - \vec{r}_c|^3}$$

This observation will be used after this example is finished. Let us now find the electric field at various other points. Let $\vec{r} = x\hat{i} + y\hat{j}$ so that the electric field at \vec{r} is

$$\begin{aligned} \vec{E}(x, y) &= \frac{q_b}{4\pi\epsilon_0} \frac{\vec{r} - \vec{r}_b}{|\vec{r} - \vec{r}_b|^3} + \frac{q_c}{4\pi\epsilon_0} \frac{\vec{r} - \vec{r}_c}{|\vec{r} - \vec{r}_c|^3} \\ &= 18 \frac{\text{N}}{\text{C}} \frac{(x - 0.8)\hat{i} + (y - 0.5)\hat{j}}{[(x - 0.8)^2 + (y - 0.5)^2]^{3/2}} - 27 \frac{\text{N}}{\text{C}} \frac{(x - 0.7)\hat{i} + (y - 0.2)\hat{j}}{[(x - 0.7)^2 + (y - 0.2)^2]^{3/2}} \end{aligned}$$

Evaluating this at a few locations we find the following.

$$\begin{aligned} \vec{E}(0, 0.4) &= (22\hat{i} - 17\hat{j}) \frac{\text{N}}{\text{C}} & \vec{E}(0, 0.1) &= (33\hat{i} - 2\hat{j}) \frac{\text{N}}{\text{C}} \\ \vec{E}(0, 0.3) &= (28\hat{i} - 14\hat{j}) \frac{\text{N}}{\text{C}} & \vec{E}(0, 0.0) &= (32\hat{i} + 3\hat{j}) \frac{\text{N}}{\text{C}} \\ \vec{E}(0, 0.2) &= (32\hat{i} - 9\hat{j}) \frac{\text{N}}{\text{C}} & \vec{E}(0, -0.1) &= (28\hat{i} + 8\hat{j}) \frac{\text{N}}{\text{C}} \end{aligned}$$

The fields at these six points are graphed as the six bold arrows on the left side of the following plot. The field is graphed at many other

points a well.

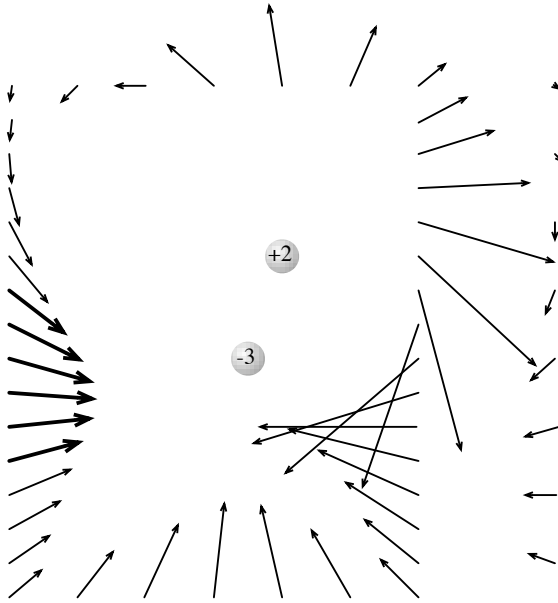

This graph gives some idea of how the field changes as you move around in the space. The graph is a little confusing in the region where the arrows cross each other. This happens wherever the field is strong. Because of this there is another kind of graph that is usually used to map out the electric field. Take a look at the following graph, which has both styles of maps together.

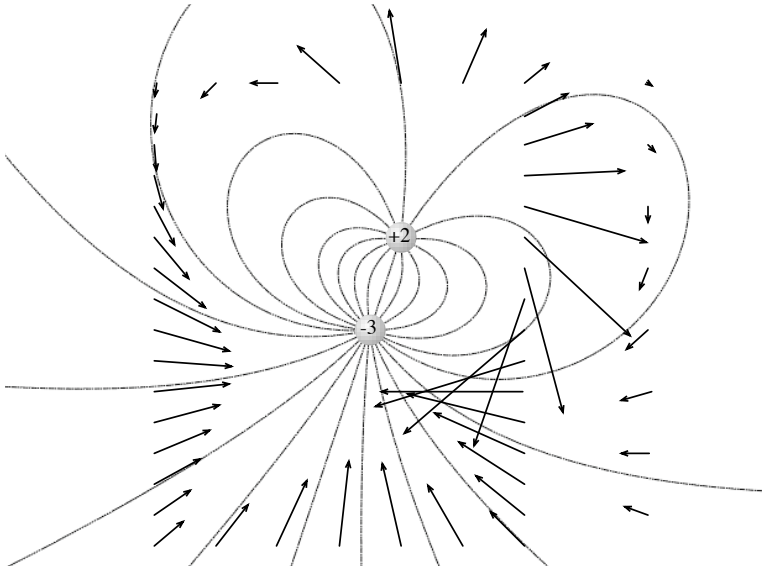

The second style has curved *field lines* that follow the direction of the electric field. Check to see that the arrows are parallel to the field lines at the base of the arrow. This type of graph clearly shows the direction of the field. You can get an idea of the magnitude of the field by how close the field lines are to each other: the field is strong where the field lines are close together. Here is a graph showing just the field lines.

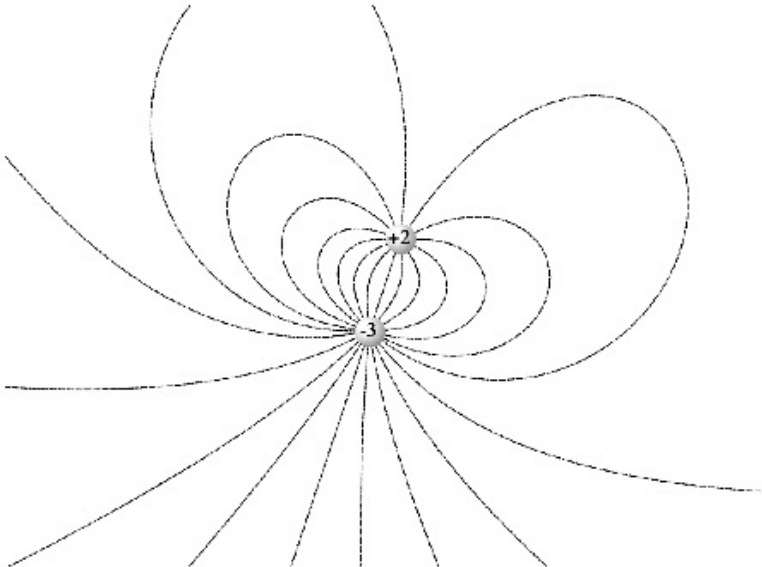

Look back now to the middle of the example, where we observed that in the calculation of the electric field the test charge q_a had dropped out of the equation. We observed, at that time, that the electric field at any location \vec{r} in space could be written out as

$$\vec{E}(\vec{r}) = \frac{q_b}{4\pi\epsilon_0} \frac{\vec{r} - \vec{r}_b}{|\vec{r} - \vec{r}_b|^3} + \frac{q_c}{4\pi\epsilon_0} \frac{\vec{r} - \vec{r}_c}{|\vec{r} - \vec{r}_c|^3}$$

We see the contribution of each source charge is of the form $\frac{q_s}{4\pi\epsilon_0} \frac{\vec{r} - \vec{r}_s}{|\vec{r} - \vec{r}_s|^3}$ and that the net field is the sum of the contributions of each source charge. This is so because the net force is the vector sum of the individual force. Following this idea we would arrive at these two theorems.

Theorem: Electric Field due to a Point Charge

The electric field at the location \vec{r} due to a point charge q_s at the location \vec{r}_s is given by the following expression.

$$\vec{E}(\vec{r}) = \frac{q_s}{4\pi\epsilon_0} \frac{\vec{r} - \vec{r}_s}{|\vec{r} - \vec{r}_s|^3}$$

The magnitude of the electric field due to a point charge at a distance r from the point charge is

$$E(r) = \frac{q}{4\pi\epsilon_0} \frac{1}{r^2}$$

Theorem: Superposition Theorem

The electric field due to a collection of point charges is the sum of the fields of the individual charges.

$$\vec{E}(\vec{r}) = \sum_n \frac{q_n}{4\pi\epsilon_0} \frac{\vec{r} - \vec{r}_n}{|\vec{r} - \vec{r}_n|^3}$$

▷ PROBLEM 1.3

A charge $q_1 = +q$ is placed at the location $\vec{r}_1 = 0\hat{i} + a\hat{j}$ and a second charge $q_2 = -q$ is placed at $\vec{r}_2 = 0\hat{i} - a\hat{j}$.

(a) Write out the electric field at an arbitrary location on the x -axis: $\vec{r} = x\hat{i} + 0\hat{j}$.

(b) Sketch a map of the electric field lines, in the first quadrant. Here is a table that gives the angle (from the positive x -axis) of the electric field at different locations in the first quadrant.

$x/a =$	0.0	0.5	1.0	1.5	2.0	2.5	3.0
$y/a = 0.0$	-90	-90	-90	-90	-90	-90	-90
0.5	-90	-54	-48	-52	-57	-61	-65
1.0	45	-3	-11	-20	-29	-36	-42
1.5	90	42	19	5	-7	-16	-23
2.0	90	61	39	23	11	1	-8
2.5	90	69	51	36	24	13	5
3.0	90	74	58	45	33	24	15

§ 1.4 Vector and Scalar Fields

Definition: **Scalar Field**

A *scalar field* is an entity that has a magnitude at each point in space.

The potential energy is a scalar field, the quantity $U = mgy$ gives the amount of potential energy at each point ($\vec{r} = x\hat{i} + y\hat{j}$) in space.

Definition: **Vector Field**

A *vector field* is an entity that has a magnitude and direction at each point in space.

Gravity is a vector field, the constant $g = 9.8\frac{\text{m}}{\text{s}^2}$ is the magnitude of the field near the surface of the earth, and the direction is toward the earth. If you move away from the surface of the earth the gravitational field decreases in strength. The gravitational field is similar to the electric field in the sense that they both give the force on a body. The gravitational field gives the force on a massive body.

$$\vec{F}_G = m\vec{g}$$

While, the electric field gives the force on a charged body.

$$\vec{F}_E = q\vec{E}$$

Definition: **Uniform Field**

A *uniform* vector field is a vector field that has the same magnitude and direction at all points in space. A uniform scalar field is a scalar field that has the same value at all points in space.

§ 1.5 Continuous Charge Distributions

In principle one could compute the electric field in any situation by summing the fields of each proton and electron in the system. In practice this is not done because there are too many electrons and protons. In this section we will see how to compute the electric field when there are too many charges to count.

Suppose that we have a string that has been rubbed on a cat until the string has built up a charge Q that is spread uniformly over the length of the string. We then take the string and stretch it out in a straight line. We wish to calculate the electric field due to the string. For convenience assume that the string is stretched out along the x -axis from $x = -L/2$ to $x = L/2$.

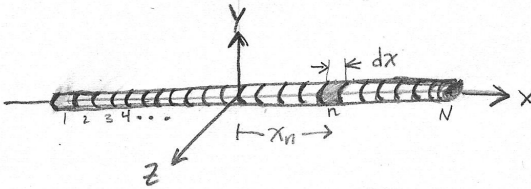

One way of finding the electric field is to conceptually break the string into short little sections, say N of them. Each of the sections will be a length $dx = L/N$, and carry a charge $dq = Q/N$. We can number the sections from 1 to N , and then the n 'th section will be at the position $\vec{r}_n = x_n \hat{i}$ ($x_n = nL/N - L/2$). As long as we break the string into enough sections so that dx is small, we can treat each section as a point charge and then we can compute the electric field as a sum of N point charges

$$\vec{E}(\vec{r}) = \sum_n \frac{q_n}{4\pi\epsilon_0} \frac{\vec{r} - \vec{r}_n}{|\vec{r} - \vec{r}_n|^3} = \sum_n \frac{dq}{4\pi\epsilon_0} \frac{\vec{r} - \vec{r}_n}{|\vec{r} - \vec{r}_n|^3}$$

Keep in mind when you look at this formula that the vector \vec{r}_n points to the charge q_n . With this formula and the aid of a computer it is possible to compute the electric field for nearly any distribution of charge that you can imagine.

It is also possible, in some cases, to find a closed form solution, without using a computer. If we take the limit as N goes to infinity, the sum becomes an integral and the electric field can be written in the form

$$\vec{E}(\vec{r}) = \int \frac{dq}{4\pi\epsilon_0} \frac{\vec{r} - \vec{r}_s}{|\vec{r} - \vec{r}_s|^3}$$

Here again we imagine that we break the object into many small pieces of charge dq , the vector \vec{r}_s points toward dq , ranging over all dq 's and

that we “sum” over all the pieces.

Let us evaluate this integral for the case of the string that we introduced earlier. First we need to relate dq to dx . The entire length L of the string has a charge Q so that the charge per length is $\lambda = Q/L$. If the charge is uniformly spread over the string we expect the charge per length to be the same everywhere so that

$$\frac{dq}{dx} = \frac{Q}{L} = \lambda \longrightarrow dq = \lambda dx$$

With this, and the fact that $\vec{r}_s = x_s \hat{i}$, we can write

$$\begin{aligned} \vec{E}(\vec{r}) &= \int \frac{dq}{4\pi\epsilon_0} \frac{\vec{r} - \vec{r}_s}{|\vec{r} - \vec{r}_s|^3} \\ &= \int_{-L/2}^{L/2} \frac{\lambda dx_s}{4\pi\epsilon_0} \frac{\vec{r} - x_s \hat{i}}{|\vec{r} - x_s \hat{i}|^3} \end{aligned}$$

If we write the field point as $\vec{r} = x\hat{i} + y\hat{j}$, and then do the integration, we find that

$$\begin{aligned} \vec{E}(x, y) &= \frac{\lambda}{4\pi\epsilon_0} \left[\frac{1}{\sqrt{y^2 + (x - \frac{L}{2})^2}} - \frac{1}{\sqrt{y^2 + (x + \frac{L}{2})^2}} \right] \hat{i} \\ &\quad + \frac{\lambda}{4\pi\epsilon_0} \frac{1}{y} \left[-\frac{x - \frac{L}{2}}{\sqrt{y^2 + (x - \frac{L}{2})^2}} + \frac{x + \frac{L}{2}}{\sqrt{y^2 + (x + \frac{L}{2})^2}} \right] \hat{j} \end{aligned}$$

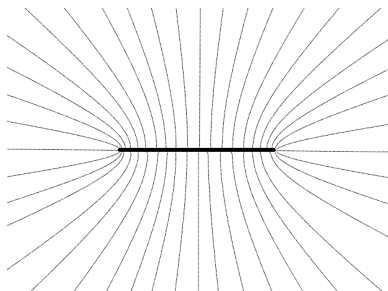

▷ PROBLEM 1.4

Suppose that you have a circular hoop of radius R with a net charge Q spread uniform around the hoop. Compute the electric field at a distance z along the axis of the hoop?

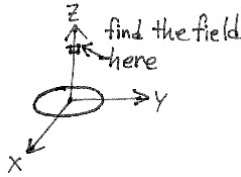

§ 1.6 Gauss's Law

We have seen that the electric field due to any charge distribution can be computed. From this relationship between the electric field and the charge distribution, another one can be derived.

First we will define a new quantity, the electric flux through a surface. To get an idea of what the flux represents first consider the following story. You wish to catch some butterflies but you don't have time to chase them around, so you just set up your butterfly net on a pole. The butterflies are migrating south for the winter. They are flying by your house heading in a southerly direction, so you orient the net so that it faces north. The number of butterflies you catch should be proportional to both the density of butterflies in the air and the area of the mouth of the net. The number of butterflies caught will also depend on the orientation of the net relative to the direction the butterflies are moving. For example, if the butterflies end up flying to the south-west instead of directly south, you will not catch as many since the net was not facing the optimal direction.

The electric flux is similar, it is the amount of electric field that "passes through" a surface. There are three things that determine the quantity of electric flux: the area of the surface, the magnitude of the electric field and the orientation of the field relative to the surface. To write this out clearly, we need to have a way to mathematically represent the orientation of a surface. We will define a vector area \vec{A} as the vector that has a magnitude equal to the area of the surface and has a direction that is normal to the surface. A good picture to keep in mind is a thumbtack,

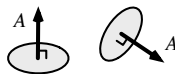

the nail part of the tack is the vector area and the flat part of the tack is the surface. This ends up being the best way to use a vector to represent a surface. Now we can define the electric flux.

Definition: Electric Flux

The *electric flux* (ϕ_e) through a surface is

$$\phi_e = \vec{E} \cdot \vec{A}$$

if the field is uniform over the surface. If the field is not uniform then one must integrate over the surface,

$$\phi_e = \int \vec{E} \cdot d\vec{A}$$

We see that the dot product represents the dependence of the flux on the relative orientation of the surface and the field. When thinking of the flux integral over a surface it can be helpful to imagine gluing tacks to the surface with the nail part sticking out, so that you end up with a spiky covering of the surface. Each tack represents one small surface element $d\vec{A}$ and the integral is the sum of the flux's through all of the small surface element.

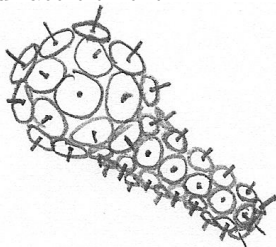

Now we can state the theorem that relates the electric field to the charge density.

Theorem: Gauss's Law

The electric flux out of any closed surface is proportional to the total charge enclosed within the surface.

$$\oint \vec{E} \cdot d\vec{A} = \frac{Q_{\text{in}}}{\epsilon_0}$$

Note that the integral of the electric field over the surface does not depend on the charge density outside the surface in any way. For example if there is no charge inside the surface then the integral must be zero.

EXAMPLE

We can use Gauss's law in order to find the electric field strength. Here is an example of how this can be done. The result of this example is also generally useful.

Suppose that you have a block of material which has charges inside that move freely. We will show later that inside the block the electric field is zero and that outside but near the block the field is normal to the surface. Also we will see later that there is no net charge inside the block, but that on the surface there can be a surface charge density. Let us form a Gaussian surface in the shape of a small tin can that is half inside and half outside the material, with the can oriented so that the ends of the can are parallel to the surface of the material.

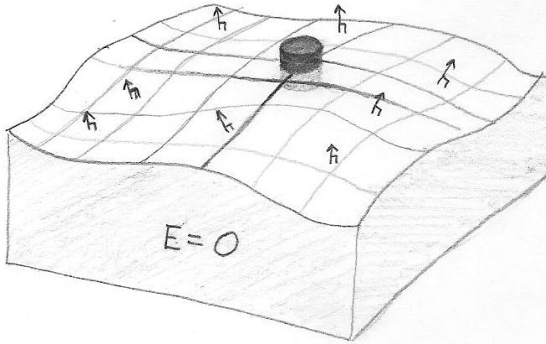

Since the field is zero inside the material we know that the flux is zero through the half of the can that is inside the material. We also know that the flux is zero through the sides of the can because the field is normal to the surface of the material. So we see that the only flux through the surface of the can is the flux through the top of the can. Assuming that the can is small enough so that the field is uniform over the can, then the flux through the top is

$$\int_{\text{top}} \vec{E} \cdot d\vec{A} = \vec{E} \cdot \vec{A} = EA$$

where A is the cross sectional area of the can. We have now computed the left hand side of Gauss's law. The right hand side is the charge inside the gaussian surface. Since the charge is only on the surface we can find the charge inside the can as the area of the surface that is inside the can A times the surface charge density σ : so $Q_{\text{in}} = A\sigma$. And

$$\begin{aligned} \oint \vec{E} \cdot d\vec{A} &= \frac{Q_{\text{in}}}{\epsilon_0} \\ \int_{\text{bottom}} \vec{E} \cdot d\vec{A} + \int_{\text{sides}} \vec{E} \cdot d\vec{A} + \int_{\text{top}} \vec{E} \cdot d\vec{A} &= \frac{Q_{\text{in}}}{\epsilon_0} \\ \longrightarrow 0 + 0 + EA &= \frac{A\sigma}{\epsilon_0} \longrightarrow E = \frac{\sigma}{\epsilon_0} \end{aligned}$$

In the previous example, the determination of the flux was greatly

simplified because we picked a the gaussian surface so that the electric field was either normal to the surface or in the plane of the surface. For example, the field was in the plane of the sides of the can in the previous example, thus the flux was zero through the sides. Further, in the previous example, the electric field was normal to the part of the gaussian surface that did not have a zero flux, in addition the field strength was uniform over this part of the surface. Thus the first thing to do, when you are using Gauss's law to find the electric field strength, is to choose the gaussian surface so that the field is either parallel or normal to all parts of the surface.

▷ PROBLEM 1.5

Four closed surfaces are near three charges as shown.

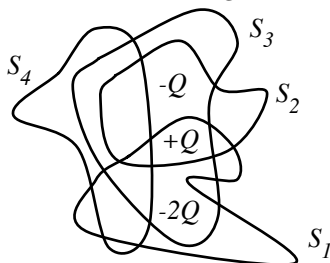

Find the electric flux through each surface.

▷ PROBLEM 1.6

A charge q is placed at one corner of a cube. What is the electric flux through each face of the cube.

▷ PROBLEM 1.7

Use Gauss's law to show that the field strength at a distance r from a point charge is $\frac{q}{4\pi\epsilon_0 r^2}$.

▷ PROBLEM 1.8

A solid sphere of radius R has a total charge of Q uniformly distributed throughout its volume. Calculate the magnitude of the electric field at a distance r from the center of the sphere. Be sure to consider the cases of $r < R$ and $r > R$ separately.

▷ PROBLEM 1.9

A sphere of radius a carries a volume charge density $\rho = \rho_0(r/a)^2$. Find the electric field inside and outside the sphere.

▷ PROBLEM 1.10

Use Gauss's law to show that the electric field near a line charge with uniform charge density λ is given by $E = \frac{\lambda}{2\pi\epsilon_0 r}$ where r is the distance from the line.

▷ PROBLEM 1.11

Consider a long cylindrical charge distribution of radius R with a uniform charge density ρ . Find the electric field at a distance r from the axis for $r < R$.

▷ PROBLEM 1.12

A spherical shell of radius R carries a net charge of Q uniformly distributed over its surface.

- (a) Find the electric field strength at a point inside the shell.
 (b) Find the electric field strength at a point outside the shell.

§ 1.7 More Examples

EXAMPLE Return to the pithballs in the example in section 1: assume the length of each string is 10cm. If the masses have the same net electric charge, what is the magnitude of the charge on each mass? Can you determine the sign of the net charge on each ball?

Use the following diagram to determine the distances between the masses:

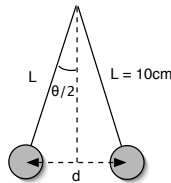

$$d = 2L \sin \frac{\theta}{2} = 2(10\text{cm}) \sin 5^\circ = 1.7\text{cm}.$$

Assume each mass has a charge q , then using Coulomb's law:

$$F_E = \frac{1}{4\pi\epsilon_0} \frac{q^2}{d^2} \longrightarrow q^2 = \frac{F_E d^2}{\frac{1}{4\pi\epsilon_0}}$$

$$\longrightarrow q = \sqrt{\frac{(0.0034\text{N})(.017\text{m})^2}{9 \times 10^9 \text{N} \cdot \text{m}^2/\text{C}^2}} = 1.0 \times 10^{-8} \text{C}$$

The sign of the charge cannot be determined; all that can be said is the net charge on the masses have the same sign.

EXAMPLE Three particles with electric charge are attached to a meter stick, as shown. The value of Q is $1 \times 10^{-6} \text{C}$ ($= 1\mu\text{C}$). (a) What is the electric force on the center charge? (b) To what position could the center charge be moved so that the net electric force on it is zero?

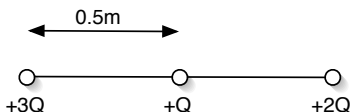

(a) The electric forces on the center charge due to the other two charges are:

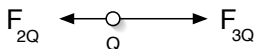

The net force is

$$\begin{aligned}
 F_{net} &= F_{3Q} - F_{2Q} \\
 &= \frac{1}{4\pi\epsilon_0} \frac{Q(3Q)}{(0.5\text{m})^2} - \frac{1}{4\pi\epsilon_0} \frac{Q(2Q)}{(0.5\text{m})^2} \\
 &= \left(9 \times 10^9 \frac{\text{N}\cdot\text{m}^2}{\text{C}^2}\right) (1 \times 10^{-6}\text{C})^2 \left(\frac{3-2}{(0.5\text{m})^2}\right) = +3.6\text{mN}
 \end{aligned}$$

(b) There are three regions to consider: in between the $2Q$ and $3Q$ charges, outside of these charges to the left and outside of these charges to the right. Here are force diagrams for placing the charge Q outside of the two larger charges:



Since the forces point in the same direction, there is no location outside of the two larger charges where the net electric force on the charge Q can be zero. For positions inside the two larger charges, the forces will point in opposite directions, as seen in part (a), and will cancel at the position where the forces have equal magnitudes. Let's measure the location from the $+3Q$ charge:

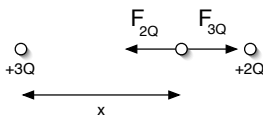

The net force on the charge $+Q$ at a position x is

$$\begin{aligned}
 F_{net} &= F_{3Q} - F_{2Q} \\
 &= \frac{1}{4\pi\epsilon_0} \frac{Q(3Q)}{x^2} - \frac{1}{4\pi\epsilon_0} \frac{Q(2Q)}{(1-x)^2}
 \end{aligned}$$

The net force is to be zero:

$$\frac{1}{4\pi\epsilon_0} \frac{Q(3Q)}{x^2} - \frac{1}{4\pi\epsilon_0} \frac{Q(2Q)}{(1-x)^2} = 0$$

$$\rightarrow 3(1-x)^2 - 2x^2 = 0$$

Solving the resulting quadratic equation yields two answers: $x = 5.45\text{m}$ and $x = 0.55\text{m}$. The latter value is the answer, since we already argued that the position must lie between the two larger charges.

⊙ Do THIS NOW 1.4

Analyze the configuration in the previous example, except replace the $+3Q$ charge with a $-3Q$ charge.

argue that the position must lie between the two larger charges.

EXAMPLE

Four charges are located at the corners of a square as shown in the diagram below. A fifth charge is located at the center of the square. For the charge values indicated compute the net electric force on the charge at the center of the square.

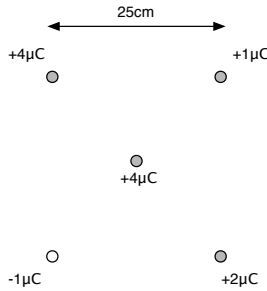

Draw a force diagram:

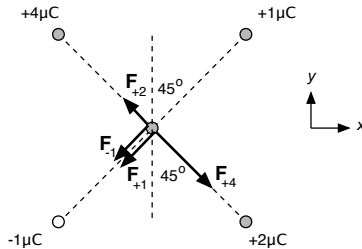

The distances between each corner charge and the center charge are the same:

$$d = \sqrt{\left(\frac{a}{2}\right)^2 + \left(\frac{a}{2}\right)^2} = \frac{\sqrt{2}}{2}a,$$

where $a = 25\text{cm}$. To find the net force, add all the forces using vector addition:

$$\vec{F}_{net} = \hat{i}F_x + \hat{j}F_y,$$

where

$$F_x = (F_{+4} - F_{+2} - F_{+1} - F_{-1}) \sin(45^\circ)$$

$$F_y = (-F_{+4} + F_{+2} - F_{+1} - F_{-1}) \cos(45^\circ)$$

Use Coulomb's law to compute the magnitude of each force:

$$F_{+4} = \frac{(9 \times 10^9)(4 \times 10^{-6})(4 \times 10^{-6})}{\left(\frac{\sqrt{2}}{2}(.25)\right)^2} = 4.6\text{N}$$

$$F_{+1} = F_{-1} = \frac{(9 \times 10^9)(1 \times 10^{-6})(4 \times 10^{-6})}{\left(\frac{\sqrt{2}}{2}(.25)\right)^2} = 1.15\text{N}$$

$$F_{+2} = \frac{(9 \times 10^9)(2 \times 10^{-6})(4 \times 10^{-6})}{\left(\frac{\sqrt{2}}{2}(.25)\right)^2} = 2.3\text{N}$$

Finally, compute the components of the net force:

$$F_x = (4.6\text{N} - 2.3\text{N} - 1.15\text{N} - 1.15\text{N}) \sin(45^\circ) = 0$$

$$F_y = (-4.6\text{N} + 2.3\text{N} - 1.15\text{N} - 1.15\text{N}) \cos(45^\circ) = -3.25\text{N}$$

So, the net force points straight down with a magnitude of 3.25N.

EXAMPLE Consider the configuration of three charges along a line as shown below. Assuming the only forces acting are mutual electric forces between the charges, show that the configuration is in equilibrium, meaning that the net force on each charge is zero.

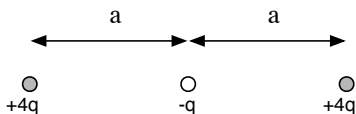

Here is a force diagram for all the charges:

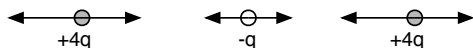

The net force on the center charge must be zero, since the two forces are in opposite directions and caused by equal charges that are the same distance away. One down, two to go. Use the force law to write

out the net force on the leftmost charge:

$$\begin{aligned} F_L &= \frac{1}{4\pi\epsilon_0} \frac{(4q)(q)}{a^2} - \frac{1}{4\pi\epsilon_0} \frac{(4q)(4q)}{(2a)^2} \\ &= \frac{1}{4\pi\epsilon_0} \frac{(4q)(q)}{a^2} - \frac{1}{4\pi\epsilon_0} \frac{(4q)(q)}{a^2} \\ &= 0 \end{aligned}$$

So the net force on the leftmost charge is zero. Since the rightmost charge is the mirror image of the leftmost charge, it also has no net force acting on it. Thus, all three charges have a net force of zero acting on them for the configuration given, and the system is in equilibrium. Is the equilibrium *stable*?

By stability we mean the following. If we move one of the charges a little bit, does the configuration return to the original equilibrium configuration, or does the configuration fall apart? Let's move one of the charges a little bit and see what happens. Move the left most charge a small distance ϵ to the left. If the configuration is stable, then the net force on it must push it to the right. Check:

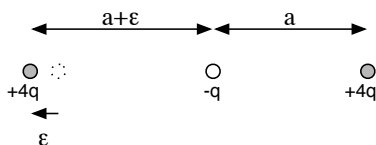

The net force is now:

$$F'_L = \frac{1}{4\pi\epsilon_0} \frac{(4q)(q)}{(a + \epsilon)^2} - \frac{1}{4\pi\epsilon_0} \frac{(4q)(4q)}{(2a + \epsilon)^2}$$

If this force points to the right, it will push the charge back from where it came and the equilibrium can be stable. If the force is to the left, the charge will be pushed away from the equilibrium position and the equilibrium can not be stable. With a little algebraic muscle the formula above for F'_L can be rewritten:

$$F'_L = \frac{q^2}{\pi\epsilon_0 a^2} \left(\frac{1}{\left(1 + \frac{\epsilon}{a}\right)^2} - \frac{1}{\left(1 + \frac{\epsilon}{2a}\right)^2} \right)$$

It is easy to see that this is a negative number since the denominator in the subtracted term is smallest, no matter how small ϵ is, as long as it is larger than zero. Thus, the force on the leftmost charge points to the left and the charge is pushed away from the original equilibrium position. The equilibrium is unstable.

Determine what the other two charges in the previous example do when the leftmost charge is moved to the left.

The charges accelerate towards each other.

⊙ Do THIS NOW 1.6

An electron accelerates east due to an electric field. What direction does the electric field point? *west*

EXAMPLE

A dust particle with mass $2\mu\text{g}$ has a net electric charge $3\mu\text{C}$. The piece of dust is in a region of uniform electric field and is observed to accelerate at a rate of $180\frac{\text{m}}{\text{s}^2}$. What is the magnitude of the electric field in that region of space?

The net force on the dust particle can be computed using Newton's second law:

$$F_{net} = (2 \times 10^{-9}\text{kg})(180\frac{\text{m}}{\text{s}^2}) = 3.6 \times 10^{-7}\text{N}.$$

Using the definition of electric field and assuming no other forces act on the dust particle:

$$E = \frac{F}{q} = \frac{3.6 \times 10^{-7}\text{N}}{3 \times 10^{-6}\text{C}} = 0.12\frac{\text{N}}{\text{C}}.$$

EXAMPLE

If a proton is placed in the same electric field from the previous example, what is the resulting acceleration?

Work backwards:

$$F = qE = (1.6 \times 10^{-19}\text{C})(0.12\text{N/C}) = 1.9 \times 10^{-20}\text{N}$$

$$a = \frac{F}{m} = \frac{1.9 \times 10^{-20}\text{N}}{1.67 \times 10^{-27}\text{kg}} = 1.15 \times 10^7\frac{\text{m}}{\text{s}^2}$$

EXAMPLE

Three charges lie along a line as shown below. What is the electric field at a position that is a horizontal distance a to the right of the $-q$ charge?

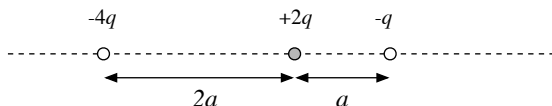

Here is a diagram indicating the electric field due to each charge at the point:

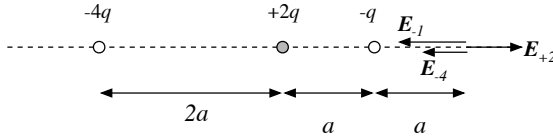

In the diagram, the electric field due to the $-4q$ charge has been labeled E_{-4} , etc. The electric field at the point indicated is just the superposition of the individual electric fields:

$$E = E_{+2} - E_{-1} - E_{-4} = \frac{1}{4\pi\epsilon_0} \frac{(2q)}{(2a)^2} - \frac{1}{4\pi\epsilon_0} \frac{q}{a^2} - \frac{1}{4\pi\epsilon_0} \frac{(4q)}{(4a)^2}$$

$$\longrightarrow E = -\frac{3}{16\pi\epsilon_0} \frac{q}{a^2}.$$

EXAMPLE

Using the configuration of charges in the previous example, determine the electric field a vertical distance a above the $+2q$ charge. First, let's add a coordinate system, since this problem will involve vectors in two dimensions:

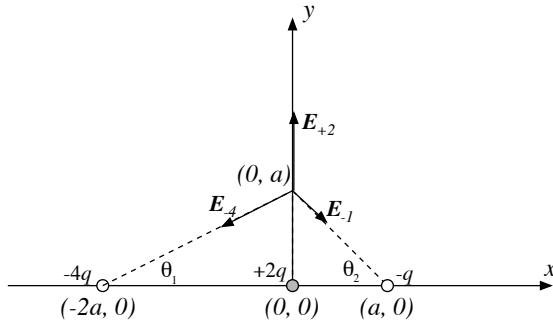

The angles θ_1 and θ_2 can be computed using some geometry:

$$\cos \theta_1 = \frac{2}{\sqrt{5}} \quad \sin \theta_1 = \frac{1}{\sqrt{5}}$$

$$\cos \theta_2 = \frac{1}{\sqrt{2}} \quad \sin \theta_2 = \frac{1}{\sqrt{2}}$$

To compute the electric field at the point $(0, a)$, we add the individual electric fields as vectors:

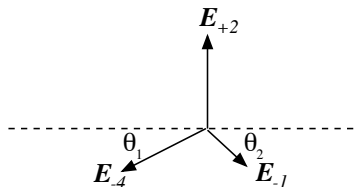

$$\begin{aligned}\vec{E} &= \hat{i}(-E_{-4} \cos \theta_1 + E_{-1} \cos \theta_2) \\ &\quad + \hat{j}(-E_{-4} \sin \theta_1 - E_{-1} \sin \theta_2 + E_{+2})\end{aligned}$$

Use Coulomb's law to compute the magnitudes of the electric field contribution from each charge:

$$E_{-4} = \frac{1}{4\pi\epsilon_0} \frac{(4q)}{(\sqrt{5}a)^2} = \frac{1}{4\pi\epsilon_0} \frac{4q}{5a^2}$$

$$E_{+2} = \frac{1}{4\pi\epsilon_0} \frac{(2q)}{a^2} = \frac{1}{4\pi\epsilon_0} \frac{2q}{a^2}$$

$$E_{-1} = \frac{1}{4\pi\epsilon_0} \frac{(q)}{(\sqrt{2}a)^2} = \frac{1}{4\pi\epsilon_0} \frac{q}{2a^2}$$

Finally,

$$\begin{aligned}\vec{E} &= \hat{i} \left(-\frac{1}{4\pi\epsilon_0} \frac{q}{5a^2} \frac{2}{\sqrt{5}} + \frac{1}{4\pi\epsilon_0} \frac{q}{2a^2} \frac{1}{\sqrt{2}} \right) \\ &\quad + \hat{j} \left(-\frac{1}{4\pi\epsilon_0} \frac{4q}{5a^2} \frac{1}{\sqrt{5}} - \frac{1}{4\pi\epsilon_0} \frac{q}{2a^2} \frac{1}{\sqrt{2}} + \frac{1}{4\pi\epsilon_0} \frac{2q}{a^2} \right) \\ &\longrightarrow \vec{E} = \frac{1}{4\pi\epsilon_0} \frac{q}{a^2} (-\hat{i}(0.36) + \hat{j}(1.29))\end{aligned}$$

Flux example:

EXAMPLE A uniform electric field passes through a $1\text{cm} \times 1\text{cm}$ square in the xy plane. The electric field is $\vec{E} = (5 \frac{\text{N}}{\text{C}})\hat{i} + (3 \frac{\text{N}}{\text{C}})\hat{k}$. What is the electric flux through the square?

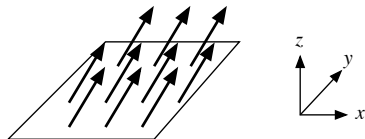

Since the electric field is constant:

$$\phi_E = \int \vec{E} \cdot d\vec{A} = \vec{E} \cdot \vec{A}.$$

The area vector points in the \hat{k} direction, so

$$\phi_E = \left(5\frac{\text{N}}{\text{C}}\hat{i} + 3\frac{\text{N}}{\text{C}}\hat{k}\right) \cdot (0.01\text{m})^2\hat{k} = 0.03\frac{\text{N}\cdot\text{m}^2}{\text{C}}$$

Gauss's Law Examples:

EXAMPLE

A $1.5 \times 10^{-9}\text{C}$ point charge is located at the center of a cylinder. The electric flux through the sides of the cylinder is known to be $100\frac{\text{N}\cdot\text{m}^2}{\text{C}}$. What is the electric flux through one of the endcaps?

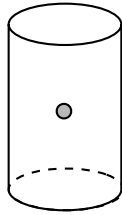

By Gauss's law:

$$\begin{aligned} \oint \vec{E} \cdot \vec{A} &= \frac{Q_{in}}{\epsilon_0} \\ \int_{sides} \vec{E} \cdot \vec{A} + \int_{caps} \vec{E} \cdot \vec{A} &= \frac{1.5 \times 10^{-9}\text{C}}{8.85 \times 10^{-12} \frac{\text{C}^2}{\text{N}\cdot\text{m}^2}} \\ 100\frac{\text{N}\cdot\text{m}^2}{\text{C}} + \int_{caps} \vec{E} \cdot \vec{A} &= 169\frac{\text{N}\cdot\text{m}^2}{\text{C}} \\ \rightarrow \int_{caps} \vec{E} \cdot \vec{A} &= 169\frac{\text{N}\cdot\text{m}^2}{\text{C}} - 100\frac{\text{N}\cdot\text{m}^2}{\text{C}} = 69\frac{\text{N}\cdot\text{m}^2}{\text{C}} \end{aligned}$$

This is the flux through both caps. Since the charge is located symmetrically with respect to the two endcaps, the flux through one cap is just half this: $34.5\frac{\text{N}\cdot\text{m}^2}{\text{C}}$.

EXAMPLE

A large, thin rectangular plate has a uniform charge density σ distributed over its area:



Assuming that the plate is so large that the electric field above and below the plate is uniform, compute the magnitude of the electric field.

With the assumptions above, symmetry tells us that the electric field will point in a direction perpendicular to the surface; for a positive charge it will point away from the plate:

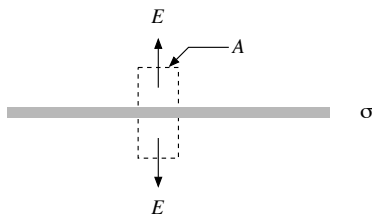

In the figure a Gaussian surface is indicated. Take it to be a small cylinder with cross-sectional area A . The electric flux is non-zero only through the endcaps:

$$\begin{aligned} \oint \vec{E} \cdot d\vec{A} &= \int_{\text{upper cap}} E \cdot d\vec{A} + \int_{\text{sides}} E \cdot d\vec{A} + \int_{\text{lower cap}} E \cdot d\vec{A} \\ &= EA + 0 + EA = 2EA \end{aligned}$$

Using Gauss's law:

$$\begin{aligned} 2EA &= \frac{\sigma A}{\epsilon_0} \\ \rightarrow E &= \frac{\sigma}{2\epsilon_0}. \end{aligned}$$

§ 1.8 Homework

▷ PROBLEM 1.13

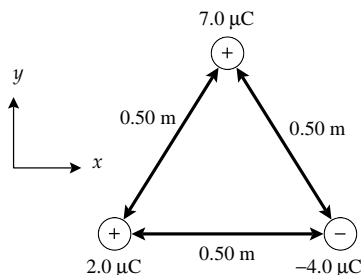

Three point charges are located at the corners of an equilateral triangle as shown. Calculate the net electric force on the $7.0\mu\text{C}$ charge.

▷ PROBLEM 1.14

Richard Feynman said that if two people were at arm's length from each other and each person had 1% more electrons than protons, the force of repulsion between them would be about equal to the "weight" of the entire Earth. Was Feynman exaggerating?

▷ PROBLEM 1.15

A point charge q is at the position (x_0, y_0) . Find the electric field at an arbitrary point (x, y) due to the charge q .

▷ PROBLEM 1.16

Two $2.0 \mu\text{C}$ charges are located on the x axis at $x = 1.0\text{m}$ and at $x = -1.0\text{m}$.

(a) Determine the electric field on the y axis at $y = 0.5\text{m}$.

(b) Calculate the electric force on a $-3.0\mu\text{C}$ charged place at this point.

▷ PROBLEM 1.17

A uniformly charged insulating rod of length 14 cm is bent into the shape of a semicircle. If the rod has a total charge of $-7.5\mu\text{C}$, find the magnitude and direction of the electric field at the center of the semicircle.

▷ PROBLEM 1.18

An electron moves at a speed of $3 \times 10^6 \frac{\text{m}}{\text{s}}$ into a uniform electric field of magnitude 1000N/C . The field is parallel to the electron's velocity and acts to decelerate the electron. How far does the electron travel before it is brought to rest?

▷ PROBLEM 1.19

A proton moves at $4.5 \times 10^5 \frac{\text{m}}{\text{s}}$ in the horizontal direction. It enters a uniform electric field of $9.6 \times 10^3 \text{N/C}$ directed downward. Ignore any gravitational effects and find the time it takes the proton to travel 5.0 cm horizontally, its vertical displacement after it has traveled 5.0 cm horizontally, and the horizontal and vertical components of its velocity after it has traveled 5.0 cm horizontally.

▷ PROBLEM 1.20

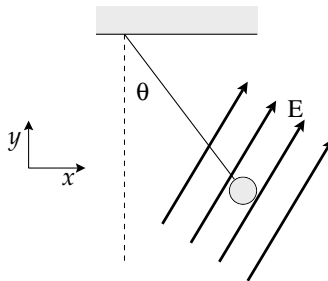

A charged ball of mass 1.00 g is suspended on a light string in the presence of a uniform electric field as shown. When $\vec{E} = (3.00\hat{i} + 5.00\hat{j}) \times 10^5 \text{ N/C}$, the ball is in equilibrium at $\theta = 37.0^\circ$.

- Find the charge on the ball.
- Find the tension in the string.

▷ PROBLEM 1.21

A triangular box is in a horizontal electric field of magnitude $E = 7.8 \times 10^4 \text{ N/C}$ as shown

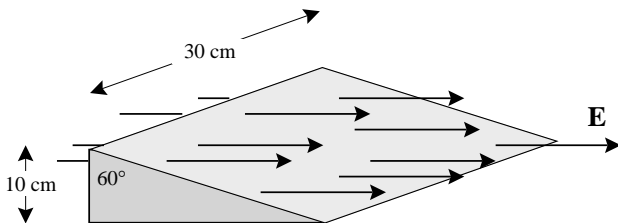

- Compute the electric flux through each face of the box.
- Compute the net electric flux through the entire surface of the box.

▷ PROBLEM 1.22

The nose cone of a rocket is in a uniform electric field of magnitude E_0 as shown.

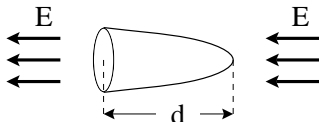

It is parabolic in cross section, of length d and of radius r . Compute the electric flux through the paraboloidal surface.

▷ PROBLEM 1.23

A charge Q is at the center of a cube of side L .

- Find the flux through each face of the cube.
- Find the flux through the entire surface of the cube.
- Would these answers change if the charge was not at the center?

▷ PROBLEM 1.24

A charge Q is located just above the center of the flat face of a solid hemisphere of radius R .

- What is the electric flux through the curved surface.
- What is the electric flux through the flat surface.

▷ PROBLEM 1.25

Find the electric field at the origin if there is a charged rod that goes from $x = a$ to $x = b$ assuming that the charge density of the rod is $\lambda = cx^n$.

§ 1.9 Summary

Definitions

Electric Field:

$$\vec{E} = \frac{\vec{F}_a}{q_a}$$

Electric Flux:

$$d\phi_e = \vec{E} \cdot d\vec{A}$$

$$\phi_e = \int \vec{E} \cdot d\vec{A}$$

Facts

Coulomb's Law

$$\vec{F}_{ab} = \frac{1}{4\pi\epsilon_0} q_a q_b \frac{\hat{r}_{ab}}{r_{ab}^2} = \frac{1}{4\pi\epsilon_0} q_a q_b \frac{\vec{r}_{ab}}{r_{ab}^3}$$

Theorems

Electric Field of a Point Charge:

$$\vec{E}(\vec{r}) = \frac{1}{4\pi\epsilon_0} q \frac{\vec{r} - \vec{r}_s}{|\vec{r} - \vec{r}_s|^3}$$

where \vec{r} points to the field point and \vec{r}_s points to the charge q .

Electric Field of a Distribution of Charge:

$$\vec{E}(\vec{r}) = \frac{1}{4\pi\epsilon_0} \int dq \frac{\vec{r} - \vec{r}_s}{|\vec{r} - \vec{r}_s|^3}$$

where \vec{r} points to the field point and \vec{r}_s points to the charge element dq .

Gauss' Law:

$$\oint \vec{E} \cdot d\vec{A} = \frac{Q_{\text{in}}}{\epsilon_0}$$

Superposition Theorem: If a charge distribution ρ_1 produces an electric field \vec{E}_1 and the charge distribution ρ_2 produces an electric field \vec{E}_2 then if both charge distributions are present the electric field is $\vec{E} = \vec{E}_1 + \vec{E}_2$.

2

Electric Potential

§ 2.1 Electric Potential

The Coulomb force is a conservative force and thus we can consider the potential energy of a particle in an electric field that is created by a static charge distribution. Suppose that you have a charged particle in an electric field, and that you move the particle from point A to point B . As the particle is moved, the electric field will do work on the particle.

$$\begin{aligned} W_{A \rightarrow B} &= \int_A^B \vec{F}_E \cdot d\vec{r} \\ &= \int_A^B q\vec{E} \cdot d\vec{r} \\ &= q \int_A^B \vec{E} \cdot d\vec{r} \end{aligned}$$

Thus when the particle is moved from A to B the change in the electric potential energy is

$$\Delta U = -W_{A \rightarrow B} = -q \int_A^B \vec{E} \cdot d\vec{r}$$

and the change in potential energy per charge is

$$\frac{\Delta U}{q} = - \int_A^B \vec{E} \cdot d\vec{r}.$$

Notice that the potential energy per charge does not depend on the test charge q , it only depends on the electric field.

Definition: Electric Potential

The *electric potential*, V , is the electric potential energy per charge.

The electric potential is related to the electric field:

$$V_B - V_A = \Delta V = \frac{\Delta U}{q} = - \int_A^B \vec{E} \cdot d\vec{r}$$

For a uniform electric field this simplifies to

$$\Delta V = \frac{\Delta U}{q} = -\vec{E} \cdot \Delta\vec{r}$$

It is important to notice that the definition of electric potential only tells us how to find the difference ($V_B - V_A$) between the electric potential at two different points, A and B . The value of the electric potential itself is not defined. This is not a problem because only the difference has physical significance. You may recall that this is true for potential energy also. The potential energy at ten meters above the surface of the earth is not defined, but the difference between the potential energy at ten meters and three meters is defined, $\Delta U = mg\Delta y$. One can choose some point in space that is defined to be the zero of the electric potential. This point is sometimes called the *ground*. Then in reference to ground, all points have an absolute electric potential. This is like choosing the surface of the earth as the zero of gravitational potential energy.

Often the electric potential is simply referred to as the potential. The units of electric potential is evidently the units of energy divided by the units of charge. This unit occurs frequently and has its own name, the Volt.

$$1\text{Volt} = \frac{1\text{Joule}}{1\text{Coulomb}}$$

This unit is abbreviated as V. Be warned that this is a bad coincidence since the symbol used for the electric potential is V , which is very similar to v . This is not a serious problem, but if you mix up the symbols, you can end up doing silly things with the algebra.

EXAMPLE Suppose that there is a uniform electric field $\vec{E} = (0.2\frac{\text{N}}{\text{C}})\hat{i}$. The electric potential difference between the two points $\vec{r}_A = (1.0\text{m})\hat{i} + (2.0\text{m})\hat{j}$ and $\vec{r}_B = (5.0\text{m})\hat{i} + (-3.0\text{m})\hat{j}$ is computed as follows.

$$\begin{aligned} V_B - V_A &= \Delta V = -\vec{E} \cdot \Delta\vec{r} \\ &= -(0.2\frac{\text{N}}{\text{C}})\hat{i} \cdot [\vec{r}_B - \vec{r}_A] \\ &= -(0.2\frac{\text{N}}{\text{C}})\hat{i} \cdot [(4.0\text{m})\hat{i} + (-5.0\text{m})\hat{j}] \\ &= -(0.2\frac{\text{N}}{\text{C}})(4.0\text{m}) + 0 = -0.8\text{V} \end{aligned}$$

This example demonstrates that the electric potential decreases as one moves in the direction of the electric field (positive x in this case). This is a general rule: the electric field points from regions of high electric potential to regions of low electric potential.

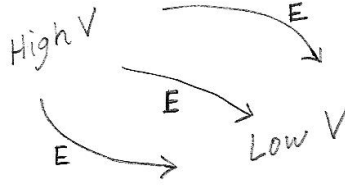

EXAMPLE Suppose that an electron moved from a region where the electric potential is 150 volts to a region where the electric potential is 100 volts. There is only the electric field acting on the electron. What would be the change in the kinetic energy of the electron? We know that the potential energy and electric potential are related: $\Delta V = \Delta U/q$.

$$\Delta K + \Delta U = 0$$

so that

$$\Delta K = -\Delta U = -q\Delta V = -(-e)(100\text{V} - 150\text{V}) = -8.0 \times 10^{-18}\text{J}$$

In this example we see that negatively charged particles slow down when they go from a region of high electric potential to a region of low electric potential. A positively charged particles would speed up.

EXAMPLE Now let's try an example where the field is not uniform.

$$\vec{E} = \alpha [y^2\hat{i} + 2xy\hat{j}]$$

If we move from the origin to the point (a, b) what is the change in the electric potential. First we need to pick a path from the starting point to the ending point. A straight line will do. Let $\vec{r}(t) = x(t)\hat{i} + y(t)\hat{j} = at\hat{i} + bt\hat{j}$, we see that as the parameter t is varied from 0 to 1, that the vector $\vec{r}(t)$ points along the path from the origin to the final point (a, b) : that is $\vec{r}(t)$ is the trajectory of a particle following our path. This function is called a *parameterization* of the path. Now we can compute the line integral $\int \vec{E} \cdot d\vec{r}$ since we can now write

$$d\vec{r} = \frac{d\vec{r}}{dt} dt = \left[\frac{dx}{dt}\hat{i} + \frac{dy}{dt}\hat{j} \right] dt = [a\hat{i} + b\hat{j}] dt$$

so that

$$\begin{aligned}
 \Delta V &= - \int_A^B \vec{E} \cdot d\vec{r} \\
 &= - \int_0^1 \vec{E}(\vec{r}(t)) \cdot \frac{d\vec{r}}{dt} dt \\
 &= - \int_0^1 \alpha [y^2 \hat{i} + 2xy \hat{j}] \cdot [a\hat{i} + b\hat{j}] dt \\
 &= -\alpha \int_0^1 [(bt)^2 \hat{i} + 2(at)(bt)\hat{j}] \cdot [a\hat{i} + b\hat{j}] dt \\
 &= -\alpha \int_0^1 [(bt)^2 a + 2(at)(bt)b] dt \\
 &= -\alpha \int_0^1 3ab^2 t^2 dt \\
 &= -\alpha ab^2
 \end{aligned}$$

In general, to compute a line integral, one must first find a parameterization of the path.

The following theorem gives a way of finding the electric field if the electric potential field is already known.

Theorem: Electric Field from the Electric Potential

$$\vec{E} = -\vec{\nabla}V = - \left[\frac{\partial V}{\partial x} \hat{i} + \frac{\partial V}{\partial y} \hat{j} + \frac{\partial V}{\partial z} \hat{k} \right]$$

The symbol $\vec{\nabla}$ represents the *gradient* operator $\frac{\partial}{\partial x} \hat{i} + \frac{\partial}{\partial y} \hat{j} + \frac{\partial}{\partial z} \hat{k}$. Thus the expression $\vec{\nabla}f$ is equal to $\frac{\partial f}{\partial x} \hat{i} + \frac{\partial f}{\partial y} \hat{j} + \frac{\partial f}{\partial z} \hat{k}$.

EXAMPLE

The nonuniform electric field, $\vec{E} = \alpha y^2 \hat{i} + 2\alpha xy \hat{j}$, that we used in the previous example, has the electric potential $V = -\alpha xy^2$. Let us check the above theorem.

$$\begin{aligned}
 \vec{E} &= -\vec{\nabla}V \\
 &= \frac{\partial}{\partial x} \alpha xy^2 \hat{i} + \frac{\partial}{\partial y} \alpha xy^2 \hat{j} + \frac{\partial}{\partial z} \alpha xy^2 \hat{k} \\
 &= \alpha y^2 \hat{i} + 2\alpha xy \hat{j} + 0 \hat{k} \quad \text{OK}
 \end{aligned}$$

▷ PROBLEM 2.1

You touch the terminals of a 9 Volt battery to your tongue. While it is touching your tongue a charge of 0.08 Coulombs passes through your tongue from one terminal to the other. How much energy is dissipated in your tongue, by the charged particles passing through it?

▷ PROBLEM 2.2

Two metal plates are held at an electric potential difference of 1000V. An electron is released from the plate that is at a lower electric potential. What is the speed of the electron when it reaches the other plate?

▷ PROBLEM 2.3

The electric field in a region is given by $\vec{E} = ay\hat{i} + ax\hat{j}$, where $a = 2.0\text{V}/\text{m}^2$ is a constant. What is the electric potential difference between the origin and the point $x = 1.0\text{m}$, $y = 2.0\text{m}$?

▷ PROBLEM 2.4

The electric potential in a region is given by $V = axyz$. What is the electric field?

§ 2.2 Equipotentials

Suppose that we have picked our zero for electric potential. Each point in space will now have it's own value for electric potential. If we put a dot at every location that is at an electric potential of, say 4.3V, then the collection of all such dots will create a surface.

Definition: Equipotential

An *equipotential* is a surface on which the electric potential is constant.

Below is a graph of a few equipotentials for the electric field produced by three point charges (front left is $q = +1$, back center is $q = +2$, and front right is $q = -3$).

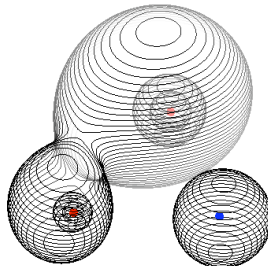

These 3D plots are difficult to generate and read, so often a section is cut through the surfaces, and only the cut edge of the surfaces are

shown. The following graph is a section through the equipotentials for the same three charges (there are a few more equipotentials drawn in this section graph).

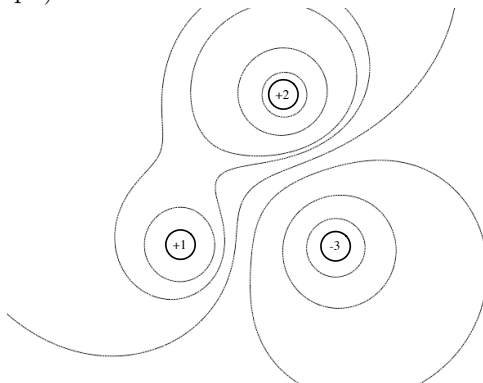

Below is a graph of the same equipotentials with a few electric field lines graphed also.

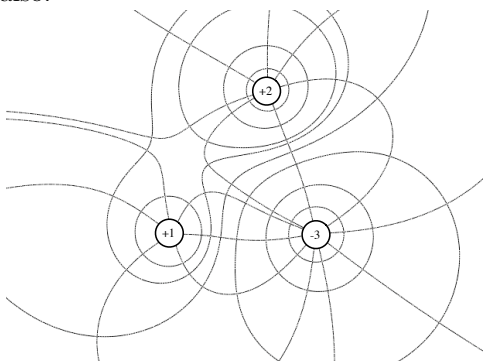

Notice that while the field lines go from positive charges to negative charges, the equipotentials encircle charges. Also notice that wherever a field line crosses an equipotential, the field line is perpendicular to the equipotential. This must happen, as we will now show. Imagine that you move a charge a small distance \vec{dr} along the surface of an equipotential. The change in electric potential must be zero since the beginning and ending points are both on the same equipotential. But we also know that the change in electric potential is given by,

$$dV = -\vec{E} \cdot \vec{dr}$$

So since $dV = 0$, it must be the case that $\vec{E} \cdot \vec{dr} = 0$, and

$$\vec{E} \cdot \vec{dr} = 0 \longrightarrow \vec{E} \text{ is perpendicular to } \vec{dr}$$

since $\vec{E} \neq 0$ and $\vec{dr} \neq 0$.

▷ PROBLEM 2.5

- (a) Sketch the equipotentials for two like charges.
- (b) Sketch the equipotentials for two opposite charges.

§ 2.3 Conductors in Equilibrium

A conductor allows its free charges to move through it with some amount of ease. So, if there is a force acting on a free charge then that charge will move. Thus if there is an electric field inside a conductor then the free charges in the conductor will move. In some situations, for example if the conductor is electrically insulated, the charges will eventually reach an equilibrium configuration in which they no longer move around. This makes sense, since if you apply a field to an isolated conductor the charges will move around to adjust to the new force but in the end they must settle down into the equilibrium configuration, which is the state with the lowest energy. But this tells us something about the electric field inside a conductor once it has reached equilibrium. Since the charges are not moving, there can be no electric field inside the conductor.

Theorem: Conductor in Equilibrium: Field

The electric field is zero inside a conductor at equilibrium.

This in turn tells us that there can be no net charge inside the volume of a conductor if the conductor is in equilibrium. We can argue this as follows. Suppose that there was a net charge in some volume inside a conductor. By Gauss's Law we know that there must be a net electric flux through the surface of this volume, but the flux is the integral of the electric field over the surface, so the electric field cannot be zero if there is a region with a net charge. But by the previous theorem we know that if there is an electric field inside a conductor then the conductor is not in equilibrium. Thus there can be a net charge inside a conductor only if the conductor is not at equilibrium.

Theorem: Conductor in Equilibrium: Charge

There is no net charge in any volume inside a conductor in equilibrium. If a charge is placed on a conductor it will reside on the surface of the conductor.

We can arrive at one more very important result by using the fact that there is no field in a conductor in equilibrium. Since the field is zero, this means that $\Delta V = -\int \vec{E} \cdot d\vec{r} = 0$ for any path inside the conductor. This tells us that a conductor in equilibrium is all at the same electric potential.

Theorem: Conductor in Equilibrium: Potential

All points in a conductor at equilibrium have the same electric potential.

Theorem: Conductor in Equilibrium: Surface Field

The field at the outside surface of a conductor in equilibrium is normal to the surface of the conductor. The magnitude of the field is $E = \frac{\sigma}{\epsilon_0}$ where σ is the surface charge density.

We can see that the previous theorem must be true by considering that the surface of the conductor is an equipotential, and noting that the electric field is normal to any equipotential surface.

▷ PROBLEM 2.6

There is a solid conductor with a cavity within it. Floating within this cavity there is a second conductor. This has been drawn below with a quarter of the outer conductor removed so that you can see the inner conductor.

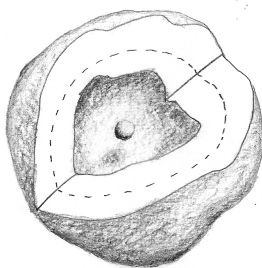

A total charge Q_a is placed on the inner conductor and a charge Q_b is placed on the outer conductor.

(a) What is the amount of charge on the inside surface of the outer conductor?

(b) What is the amount of charge on the outer surface of the outer conductor?

▷ PROBLEM 2.7

A conducting spherical shell having an inner radius of 4.0 cm and outer radius of 5.0 cm carries a net charge of $+10\mu\text{C}$. If a $+2.0\mu\text{C}$ point charge is placed at the center of this shell, determine the surface charge density on the inner and outer surfaces.

§ 2.4 Capacitors

Suppose that we place two conductors near each other. Now suppose that we remove a quantity of charge Q from one conductor and place it on the other. One conductor will end up with a charge $+Q$ and the other will end up with a charge $-Q$. In addition an electric field will be created between the conductors.

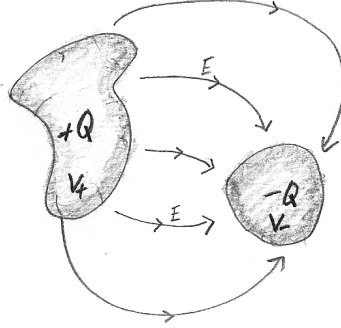

Since there is an electric field between the conductors, there will also be an electric potential difference between the two conductors.

$$\Delta V = V_+ - V_- = - \int_{\vec{r}_-}^{\vec{r}_+} \vec{E} \cdot d\vec{r}$$

Because the electric field strength is proportional to the charge Q , the electric potential difference will also be proportional to Q .

$$\Delta V \propto Q$$

EXAMPLE

Here is a specific example of this general result. Place two conducting plates parallel to each other as shown, and charge the top plate to a net charge Q and the other plate to a net charge $-Q$

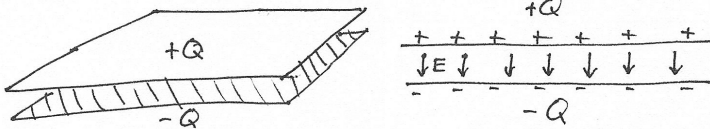

In a previous example it was shown that the electric field strength near a plate with uniform charge density σ is $E = \sigma/2\epsilon_0$. Between the plates the fields of the two plates are in the same direction (toward the negatively charged plate) so that the strength of the net field is twice the field strength of each plate alone. So the net field between the plates is $E = \sigma/\epsilon_0$. If the area of the plate is A then the charge

density is $\sigma = Q/A$ so that we find,

$$E = \frac{Q}{A\epsilon_0}$$

As long as the separation between the plates d is much less than the width of the plates the electric field will be effectively uniform between the plates, so that the potential difference between the plates is

$$\Delta V = V_+ - V_- = -\vec{E} \cdot \Delta\vec{r}$$

Since $\Delta\vec{r}$ points from the negative plate to the positive plate and \vec{E} points the opposite direction, the dot product of these two vectors is negative the product of the magnitudes; $\vec{E} \cdot \Delta\vec{r} = -Ed$.

$$\Delta V = -(-Ed) = \frac{Q}{A\epsilon_0}d = \frac{d}{A\epsilon_0}Q$$

We see then that the electric potential difference is proportional to the charge on the plates.

Since the electric potential difference is proportional to the charge, the ratio $\frac{Q}{\Delta V}$ is a constant.

Definition: Capacitance

The *capacitance*, C , of two conductors is the ratio of the charge on the conductors to the electric potential difference.

$$C = \frac{Q}{\Delta V} \quad \text{or} \quad Q = C \Delta V$$

The unit of capacitance is a *Farad* and is equal to a Coulomb per Volt: $F = \frac{C}{V}$.

▷ PROBLEM 2.8

A $6.0\mu F$ capacitor is connected to a 1.5 Volt battery so that a electric potential difference of 1.5 volts is maintained between the two conductors of the capacitor. What is the charge on each of the conductors?

▷ PROBLEM 2.9

Show that the capacitance of two parallel plates is $C = \epsilon_0 A/d$, where d is the distance between the plates and A is the area of the plates.

▷ PROBLEM 2.10

Show that the capacitance of two concentric spherical conducting shells is $\frac{4\pi\epsilon_0}{1/a - 1/b}$, where a and b are the radii of the shells.

▷ PROBLEM 2.11

Coaxial cables are commonly used to carry high frequency signals. Your cable for your cable-TV is a coaxial cable. A coaxial cable consists of

a wire (radius a) surrounded by a cylindrical conducting shield (radius b) Show that the capacitance for a length L of coaxial cable is $\frac{2\pi\epsilon_0 L}{\ln(b/a)}$.

▷ PROBLEM 2.12

Consider two long, parallel, and oppositely charged wires of radius a with their centers separated by a distance b . Assuming the charge is distributed uniformly on the surface of each wire, show that the capacitance per unit length of this pair of wires is

$$\frac{C}{\ell} = \frac{\pi\epsilon_0}{\ln(\frac{b}{a} - 1)}$$

§ 2.5 Energy in an Electric Field

Let us consider how much work must be done to charge a capacitor. Suppose that we have already moved an amount of charge q from the negative plate to the positive plate of the capacitor, so that the electric potential difference between the plates is $\Delta V = q/C$. In order to move a little bit more charge dq to the positive plate, we need to do an amount of work

$$dW = dU = dq \Delta V = dq \frac{q}{C}$$

The total amount of work to bring the capacitor from a charge of $q = 0$ to a charge of $q = Q$ is

$$U = \int_0^Q dq \frac{q}{C} = \frac{Q^2}{2C} = \frac{(C\Delta V)^2}{2C} = \frac{1}{2}C(\Delta V)^2$$

Theorem: **Energy Stored in a Capacitor**

A capacitor charged to an electric potential difference of V_C stores an amount of energy

$$U = \frac{1}{2}CV_C^2$$

This energy is stored in the electric field that has been created between the plates. The energy density (energy per volume) is

$$u = \frac{\text{energy}}{\text{volume}} = \frac{\frac{1}{2}C(\Delta V)^2}{\mathcal{V}} = \frac{\frac{1}{2}\frac{\epsilon_0 A}{d}(Ed)^2}{A d} = \frac{1}{2}\epsilon_0 E^2$$

In the intermediate step in the above equation, the properties of a parallel plate capacitor was used, but the final result is true in general.

Theorem: **Energy Density of an Electric Field**

The electric field contains an amount of energy per volume u .

$$u = \frac{1}{2}\epsilon_0 E^2$$

▷ PROBLEM 2.13

A $120\mu\text{F}$ capacitor is charged to an electric potential difference of 100V.

(a) How much energy is stored in the capacitor?

(b) If the field strength in a capacitor becomes too great then the charge will jump across the gap between the plates. Assume that this breakdown occurs when the field strength reaches $3 \times 10^6 \frac{\text{V}}{\text{m}}$. What is the minimum volume that is required for a $120\mu\text{F}$ capacitor to be able to hold an electric potential difference of 100V?

§ 2.6 Electric Potential of a Point Charge

We wish to find the electric potential for a point charge. The electric field strength around a point charge is

$$E = \frac{q}{4\pi\epsilon_0 r^2}$$

where r is the distance from the point charge. The electric field is either pointed away or toward the charge depending on if the charge is positive or negative. Let us start with the positive charge.

$$V_b - V_a = - \int_{r_a}^{r_b} \vec{E} \cdot d\vec{r}$$

If we let $r_b > r_a$ then $d\vec{r}$ is pointed outward. This is the same direction as \vec{E} so that $\vec{E} \cdot d\vec{r} = E dr$. Thus

$$\begin{aligned} V_b - V_a &= - \int_{r_a}^{r_b} E dr = - \frac{q}{4\pi\epsilon_0} \int_{r_a}^{r_b} \frac{1}{r^2} dr = - \frac{q}{4\pi\epsilon_0} \left[-\frac{1}{r} \right]_{r_a}^{r_b} \\ &= \frac{q}{4\pi\epsilon_0} \frac{1}{r_b} - \frac{q}{4\pi\epsilon_0} \frac{1}{r_a} \end{aligned}$$

Thus we see that the electric potential at a distance r from a point charge is

$$V(r) = \frac{q}{4\pi\epsilon_0} \frac{1}{r} + \text{constant}$$

For simplicity one normally chooses for the constant to be zero. Note that this choice for the constant implies that the zero of the electric potential is at the position $r = \infty$.

Theorem: Electric Potential of a Point Charge

$$V(r) = \frac{q}{4\pi\epsilon_0} \frac{1}{r}$$

▷ PROBLEM 2.14

Show that $V(r) = \frac{q}{4\pi\epsilon_0} \frac{1}{r}$ is correct for a negative charge as well.

▷ PROBLEM 2.15

An electron is released from a distance of 2.0 cm from a proton. How fast will the electron be going when it is 0.5 cm from the proton? (Assume that the proton does not move.)

§ 2.7 More Examples

EXAMPLE

An electric field is given by $\vec{E} = (3\frac{\text{N}}{\text{C}\cdot\text{m}^2})x^2\hat{i}$. What is the electric potential difference between the points (1m, 0, 0) and (3m, 0, 0)? What is the minimum work needed to move a $+6\mu\text{C}$ charge between the two points, starting from (1m, 0, 0)?

Since the electric potential is path independent (it comes from a conservative force), we can integrate along any path we want; choose the x -axis:

$$\Delta V = - \int \vec{E} \cdot (i dx) = - \int_{1\text{m}}^{3\text{m}} \left(3 \frac{\text{N}}{\text{C}\cdot\text{m}^2} \right) x^2 dx$$

$$\longrightarrow \Delta V = - \left(3 \frac{\text{N}}{\text{C}\cdot\text{m}^2} \right) \left[\frac{x^3}{3} \right]_1^3 = -26 \frac{\text{N}\cdot\text{m}}{\text{C}} = -26\text{V}$$

The work done by an external agent will be

$$W = -W_E = q\Delta V = (6 \times 10^{-6})(-26\text{V}) = -1.56 \times 10^{-4}\text{J}$$

EXAMPLE

The figure below is a schematic representation of an electron “gun.” A potential difference is maintained between the left and right plates, with the right plate having a higher potential. By heating the left plate, an electron is “boiled” off the plate. The electron, starting from rest, then moves toward the right plate, directed toward a small hole in the plate so that it “shoots” out of the gun. If the potential difference between the plates is 9V, how fast will the electron be moving when it reaches the right plate?

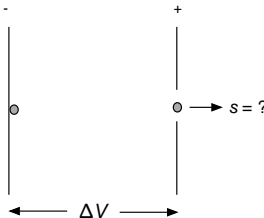

The change in potential energy of the electron will be:

$$\Delta U = q\Delta V = (-e)\Delta V.$$

Use conservation of energy:

$$\Delta U + \Delta K = -e\Delta V + (\frac{1}{2}m_e v^2 - 0) = 0$$

$$\begin{aligned} \rightarrow v &= \sqrt{\frac{2e\Delta V}{m_e}} = \sqrt{\frac{2(1.6 \times 10^{-19}\text{C})(+9\text{V})}{9.11 \times 10^{-31}\text{kg}}} \\ &= 1.78 \times 10^6 \frac{\text{m}}{\text{s}} \end{aligned}$$

EXAMPLE Near the surface of the Earth, there is always a background electric field that averages 100N/C and points down. Assuming the Earth to be a perfect conductor, how much electric charge is stored on the Earth's surface?

Since the electric field points down, we know the Earth's charge is negative. So, lets find the magnitude. Use the previous result to determine the surface charge density:

$$E = \frac{\sigma}{\epsilon_0} \rightarrow \sigma = E\epsilon_0.$$

Multiply this by the Earth's surface area to get the total charge:

$$Q_E = \sigma(4\pi R_E^2) = E\epsilon_0(4\pi R_E^2) = 453,000\text{C}$$

EXAMPLE Two equal and opposite charges are located a distance a apart. Find the electric field and the electric potential at a) the point directly between the two charges and b) the point a distance $a/2$ directly above the point inbetween the two charges.

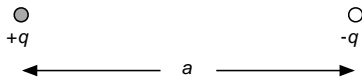

The electric fields due to each charge point in the same direction at the center point c :

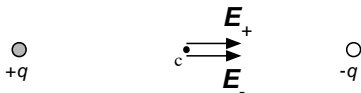

The resulting electric field at c is

$$\begin{aligned} E_c &= E_+ + E_- \\ &= \frac{1}{4\pi\epsilon_0} \frac{q}{\left(\frac{a}{2}\right)^2} + \frac{1}{4\pi\epsilon_0} \frac{q}{\left(\frac{a}{2}\right)^2} \\ &= \frac{2q}{\pi\epsilon_0 a^2} \end{aligned}$$

To find the potential we will have to come up with a rule for what to do with more than a single point charge. As just illustrated, for the electric field due to a system of charges, the resulting field at any point is just the superposition of the electric fields due to all charges at that point:

$$\vec{E} = \vec{E}_1 + \vec{E}_2 + \vec{E}_3 + \dots$$

This followed because the electric field came from a net force. Likewise, because the electric potential is defined using the electric field, at any point in space we will just add up the potentials due to all the individual charges to find the resulting potential:

$$V = V_1 + V_2 + V_3 + \dots$$

For our problem:

$$\begin{aligned} V_c &= V_+ + V_- \\ &= \frac{1}{4\pi\epsilon_0} \frac{q}{\left(\frac{a}{2}\right)} + \frac{1}{4\pi\epsilon_0} \frac{(-q)}{\left(\frac{a}{2}\right)} \\ &= 0 \end{aligned}$$

Now repeat the analysis for the second point, labeled d :

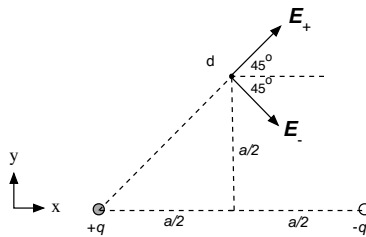

The electric field is

$$\vec{E}_d = \hat{i}(E_+ + E_-) \cos 45^\circ + \hat{j}(E_+ - E_-) \sin 45^\circ$$

Compute the magnitudes of the individual fields:

$$\begin{aligned} E_+ &= E_- = \frac{1}{4\pi\epsilon_0} \frac{q}{\left(\frac{\sqrt{2}}{2}a\right)^2} \\ &= \frac{q}{2\pi\epsilon_0 a^2} \end{aligned}$$

And,

$$\vec{E}_d = \hat{i}(2E_+) + \hat{j}(0)$$

$$E_d = 2 \frac{q}{2\pi\epsilon_0 a^2} \frac{\sqrt{2}}{2} = \frac{\sqrt{2}q}{2\pi\epsilon_0 a^2}$$

The potential is:

$$V_d = V_+ + V_- = \frac{1}{4\pi\epsilon_0} \left(\frac{q}{(\frac{\sqrt{2}}{2}a)} + \frac{(-q)}{(\frac{\sqrt{2}}{2}a)} \right)$$

$$= 0$$

The potential is zero at both points! The electric field is not zero, and it points in the x direction at both points. You should be able to argue for any point lying on the line defined by the points c and d that the electric field always points in the x direction and the potential is always zero.

⊙ Do THIS NOW 2.1

For the configuration in the previous example, compute the electric potential at a point that is distance a above the $+q$ charge.

$$\left(\frac{Q}{4\pi\epsilon_0} - \frac{Q}{4\pi\epsilon_0} \right) \frac{1}{a}$$

EXAMPLE A charge Q is distributed uniformly along a line L that lies along the x -axis. Compute the electric potential a distance x from the left end of the charge distribution that is on the x -axis. Take the potential at ∞ to be zero.

Locate the origin at the point we want to compute the electric potential (labeled P):

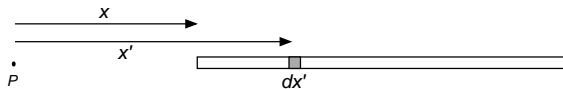

Consider the very small section of length dx' of the line that is at x' . The amount of charge contained in this small section is

$$dq' = \frac{Q}{L} dx'$$

Since the section is very small, we can treat it as a point charge and the potential it causes at P is

$$dV' = \frac{1}{4\pi\epsilon_0} \frac{Q}{L} \frac{dx'}{x'}$$

where we have used the potential for a point charge, which takes the potential at ∞ to be zero. To find the total electric potential at P we

add up potential due to each small section making up the entire line:

$$\begin{aligned} V(x) &= \int dV' = \int_x^{x+L} \frac{1}{4\pi\epsilon_0} \frac{Q}{L} \frac{dx'}{x'} \\ &= \frac{Q}{4\pi\epsilon_0 L} \ln\left(\frac{x+L}{x}\right) \end{aligned}$$

Let's check that this gives the expected result for $L \rightarrow 0$, which will result in Q being a point charge. We need the limit:

$$\lim_{L \rightarrow 0} \ln\left(\frac{x+L}{x}\right) = \lim_{L \rightarrow 0} \ln\left(1 + \frac{L}{x}\right) \approx \frac{L}{x}$$

So

$$\lim_{L \rightarrow 0} V(x) = \frac{Q}{4\pi\epsilon_0 L} \cdot \frac{L}{x} = \frac{Q}{4\pi\epsilon_0 x},$$

which is indeed the electric potential a distance x from a point charge Q .

§ 2.8 Homework

▷ PROBLEM 2.16

Through what potential difference would an electron need to be accelerated for it to achieve a speed of 40% of the speed of light, starting from rest?

▷ PROBLEM 2.17

How much work is required to move one mole of electrons from a region where the electric potential is 9V to a region where the electric potential is -5V?

▷ PROBLEM 2.18

An electron moving along the x axis has an initial speed of $2.7 \times 10^6 \frac{\text{m}}{\text{s}}$ at the origin. Its speed is reduced to $1.4 \times 10^5 \frac{\text{m}}{\text{s}}$ at the point $x = 2.0\text{cm}$. Calculate the potential difference between the origin and this point. Which point is at the higher potential?

▷ PROBLEM 2.19

In Rutherford's experiments alpha particles (charge $+2e$, mass $6.6 \times 10^{-27}\text{kg}$) were fired at a gold nucleus (charge $+79e$). An alpha particle initially very far from the gold nucleus is fired at $2.0 \times 10^7 \frac{\text{m}}{\text{s}}$ directly toward the center of the nucleus. How close does the alpha particle get to this center before turning around?

▷ PROBLEM 2.20

Show that the amount of work required to assemble four identical charges Q at the corners of a square of side s is $5.41kQ^2/s$.

▷ PROBLEM 2.21

In a certain region of space the electric potential is $V = 5x - 3x^2y + 2yz^2$. Find the expressions for the x , y , and z components of the electric field in this region. What is the magnitude of the field at the point P , which has coordinates $(1, 0, -2)\text{m}$?

▷ PROBLEM 2.22

A rod of length L lies along the x axis with its left end at the origin and has a nonuniform charge density $\lambda = \alpha x$. What are the units of α ? Calculate the electric potential at the point $x = -b$ on the x axis.

▷ PROBLEM 2.23

A wire that has a uniform linear charge density λ is bent into the shape shown below. Find the electric potential at the center of the circular part.

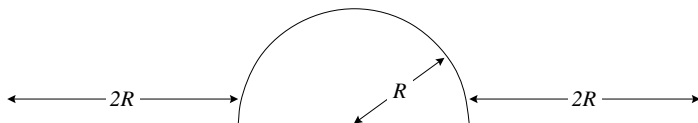

▷ PROBLEM 2.24

There is a point charge near by. You determine that the electric potential at your location (due to the point charge) is 3000V and the electric field strength is $500 \frac{\text{V}}{\text{m}}$.

- How far away is the charge?
- What is the value of the charge?

▷ PROBLEM 2.25

Three charges are placed on the x -axis. Two charges Q at $x = d$ and $x = -d$, and a third charge $-2Q$ at $x = 0$.

- Show that the electric potential along the x -axis is $V = \frac{2kQd^2}{x(x^2-d^2)}$.
- Show that the electric field along the x -axis is $\vec{E} = \frac{2kQd^2(3x^2-d^2)}{x^2(x^2-d^2)^2} \hat{i}$.
- In the limit that $x \gg d$, show that the field is proportional to $1/x^4$ and that the potential is proportional to $1/x^3$.

▷ PROBLEM 2.26

You have drop of conductive fluid with a net charge of Q_0 and a radius r_0 . The electric field and electric potential at the surface of this drop (due to the charge on the drop) are E_0 and V_0 . Two such drops join together to form a larger drop.

- What is the radius of the larger drop?
- What is the surface charge density of the larger drop?
- What is the electric field at the surface of the larger drop?
- What is the electric potential at the surface of the larger drop?

▷ PROBLEM 2.27

How much work is required to bring a total charge Q to a spherical shell of radius R ?

▷ PROBLEM 2.28

You have two concentric spherical shells of radius a and b . The smaller shell has a charge of $q_1 = 10\text{nC}$ and the larger shell has a charge of $q_2 = -15\text{nC}$.

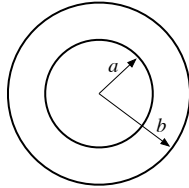

- Find the electric field at all points in space.
- Find the electric potential at all points in space.
- Sketch the electric potential as a function of the distance from the center of the shells, for $a = 0.15\text{m}$ and $b = 0.30\text{m}$.

▷ PROBLEM 2.29

Two conductors having net charges of $+10.0\mu\text{C}$ and $-10.0\mu\text{C}$ have a potential difference of 10.0V . Determine the capacitance of the system and the potential difference between the two conductors if the charges on each are increased to $+100.0\mu\text{C}$ and $-100.0\mu\text{C}$.

▷ PROBLEM 2.30

Two conductors insulated from each other are charged by transferring electrons from one conductor to the other. After 1.6×10^{12} electrons have been transferred, the potential difference between the conductors is 14V . What is the capacitance of the system?

▷ PROBLEM 2.31

Einstein showed that energy is associated with mass according to the famous relationship, $E = mc^2$. Estimate the radius of an electron, assuming that its charge is distributed uniformly over the surface of a sphere of radius R and that the mass-energy of the electron is equal to the total energy stored in the resulting nonzero electric field between R and infinity.

§ 2.9 Summary

Definitions

Electric Potential:

$$\Delta V = \frac{\Delta U}{q}$$

Capacitance:

$$C = \frac{Q}{\Delta V}$$

Equipotential: an equipotential is a surface over which the electric potential is a constant.

Theorems

$$dV = -\vec{E} \cdot d\vec{r}$$

$$\Delta V = - \int_{r_i}^{r_f} \vec{E} \cdot d\vec{r}$$

$$\vec{E} = - \left[\frac{\partial V}{\partial x} \hat{i} + \frac{\partial V}{\partial y} \hat{j} + \frac{\partial V}{\partial z} \hat{k} \right] \equiv -\vec{\nabla} V$$

Conductors in Equilibrium:

- Field - the field is zero in the volume of a conductor, and at the surface it is normal to the surface.
- Charge - the net charge in the volume of a conductor is zero.
- Potential - the potential in the volume of a conductor is constant.

Electric Potential of a Point Charge:

$$V = \frac{1}{4\pi\epsilon_0} \frac{q}{r}$$

Electric Potential of a Distributed Charge:

$$V(\vec{r}) = \frac{1}{4\pi\epsilon_0} \int \frac{dq}{|\vec{r} - \vec{r}_s|}$$

Energy Density of an Electric Field

$$E = \frac{1}{2} \epsilon_0 E^2$$

Energy Stored on a Capacitor:

$$U = \frac{1}{2} CV_C^2$$

3	Circuits
---	----------

§ 3.1 Introduction

When you turn on a flashlight, a flow of electrons is passed through the light bulb. Inside the light bulb is a small filament. As the electrons pass through the filament they lose energy and in the process the filament heats up. The filament gets so hot that it glows, this is how the bulb produces light.

The electrons are supplied from the negative terminal of the battery and flow to the light bulb through a metal wire. After the electrons pass through the filament they are carried back to the positive terminal of the battery by another wire.

A system of electrical devices connected with wires, such as the flashlight system, is called an electric circuit. Circuits are often represented in a *wiring diagram*. The following circuit diagram represents the flashlight system.

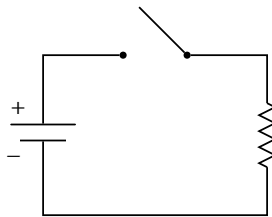

In this diagram there are three *elements* and the wires that connect them. The element on the left is the battery, with the positive terminal being wider and marked with a + sign. The element on the top is the switch that turns the flashlight off and on. The element on the right is the light bulb.

This chapter will be an investigation of electrical circuits and the common electrical devices from which circuits are built.

§ 3.2 Electric Current

A flow of charge, such as the charge flowing through the light bulb filament, is called an electric current.

Definition: Current

The electric *current*, I , is defined to be the amount of charge that flows per time.

$$I = \frac{dq}{dt}$$

The unit of current is coulombs per second. This combination of units is called the Ampere or Amp, abbreviated as just A: ($1\text{A} = \frac{1\text{C}}{1\text{s}}$).

**Definition: Current Density**

Let A be a small area that is normal to the flow of current in a particular region. Let I be the current flowing through the area A . The *current density*, \vec{J} , is a vector in the direction of the flow of current. The magnitude of the current density is equal to the current per area.

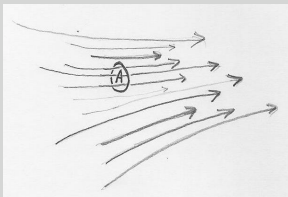

$$J = \frac{I}{A}$$

▷ PROBLEM 3.1

A light bulb draws a current of 1.0 mA from a battery.

- How many electrons pass through the bulb in 160 seconds?
- The filament has a radius of 0.20 mm. What is the current density through the filament?

§ 3.3 Ohm's Law

When an electric field is applied to a conductor the free charges in the conductor begin to move. If the conductor is isolated the charges will distribute themselves so that the field inside the conductor is zero and then the charges will cease to move. On the other hand, if the conductor is not isolated but part of a circuit, as the filament was in the flashlight circuit, then a continual flow of charge can be sustained, and the electric field in the conductor will not be zero.

Some materials, such a copper, allow charge to pass through it with very little resistance, and therefore it takes very little electric field to sustain a large current. Other materials, such a carbon, resist the flow of charge, and it requires more electric field to sustain the same current. Carbon is more resistive. This property is quantified in the following law.

Fact: Ohm's Law: Resistivity

For many materials the current density and the electric field are proportional.

$$\vec{J} = \sigma \vec{E}$$

The constant σ is called the *conductivity* and depends on the material. The inverse of the conductivity is called the *resistivity*: $\rho = 1/\sigma$.

Not all materials follow this relationship: those that do are called *ohmic* materials, those that do not are called *non-ohmic*.

Here is a table with the resistivity of a few materials.

Material	Resistivity($\times 10^{-8}\Omega \cdot \text{m}$)
Silver	1.6
Copper	1.7
Aluminum	2.8
Tungsten	5.5
Iron	10
Nichrome	100
Carbon	3500
Silcon	64000000000
Wood	1000000000000000
Amber	5000000000000000000000



Imagine a piece of conductive material, with two terminals connected to it, and with a current I passing into the material through terminal a and draining out through terminal b . Such a circuit element is called a *Resistor*.

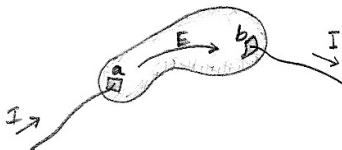

In order to sustain this current there will need to be an electric field in the conductor going from terminal a to terminal b . Thus there will

be an electric potential difference $\Delta V = V_a - V_b = -\int_b^a \vec{E} \cdot d\vec{r}$ between the two terminals. It can be shown that, regardless of the shape of the conductors, this electric potential difference is proportional to the current if the material is ohmic.

Theorem: Ohm's Law: Resistance

$$\Delta V = IR$$

Where R is called the *resistance* of the element.

The unit of resistance is the *ohm* which is one volts per amp. The ohm is abbreviated as Ω , so that $1\Omega = 1\text{V}/1\text{A}$.

▷ PROBLEM 3.2

You have a wire with cross sectional area A and length L . Show that if the terminals are placed at the ends of this conductor that the resistance of this element is $R = \rho \frac{L}{A}$.

▷ PROBLEM 3.3

You have a block of carbon, with sides of length a , $2a$, and $3a$. If terminals are placed on two parallel sides we can make a resistor with this block. We have three choices for the placement of the terminals, the sides that are a apart, $2a$ apart or $3a$ apart.

- Which choice will produce the most resistance.
- Which choice will produce the least resistance.

§ 3.4 Electric Power

Suppose that you have a circuit element with two terminals, that has a current I running through it and a potential difference ΔV between the terminals. In a time dt an amount of charge $dq = I dt$ will pass through the element. All of that charge falls through the electric potential difference of ΔV so that the charge dq loses an amount of potential energy

$$dU = dq \Delta V = I dt \Delta V \longrightarrow \frac{dU}{dt} = I \Delta V.$$

So we see that the element dissipates a power $P = I \Delta V$.

Theorem: Electrical Power

The power dissipated in a circuit element is equal to the product of the current through the element and the potential difference between the terminals of the element.

$$P = I \Delta V$$

▷ PROBLEM 3.4

A 60 Watt light bulb is plugged into the wall receptacle which supplies an electric potential of 120 Volts. How much current runs through the bulb when you turn it on?

▷ PROBLEM 3.5

(a) Show that a resistor with a current I running through it has a power of $P = I^2 R$.

(b) Show that a resistor with a voltage ΔV across it has a power of $P = (\Delta V)^2/R$.

§ 3.5 Kirchhoff's Rules

There are two theorems that are very useful in analysing a circuit. The first theorem stems from the conservation of charge, that is, that charge is neither created nor destroyed in a circuit. Consider a junction where a number of elements come together.

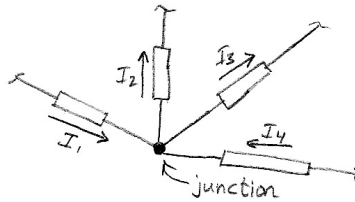

Since the current does not build up at the junction the sum of current going into the junction must be equal to the sum of the current going out of the junction. In the case pictured above: $I_1 + I_4 = I_2 + I_3$.

Theorem: **Kirchhoff's Junction Rule**

The sum of the currents into a junction is equal to the sum of the current out of a junction.

$$\sum I_{\text{in}} = \sum I_{\text{out}}$$

The second theorem stems from the conservation of energy. Since the electric potential is the potential energy per charge that is due to the electric field in the system, if a charge moves around a loop in a circuit and comes back to where it started it must be at the same electric potential as when it started. Thus if we add the electric potential differences of all the elements that are crossed as you go around any loop in the circuit the sum must be zero.

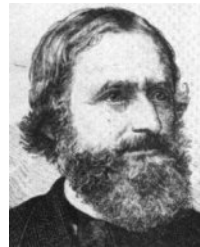

Theorem: Kirchhoff's Loop Rule

The sum of the electric potential differences around any closed loop in a circuit is zero.

$$\sum \Delta V = 0$$

As an example consider the following circuit with five elements.

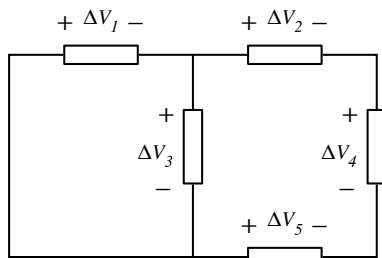

There are a number of loop rules that we could write down. First, consider the loop starting at the bottom left corner and then taking the shortest route going clockwise back to the bottom left corner. You cross elements 1 and 3, both time going from high to low potential.

$$-\Delta V_1 - \Delta V_3 = 0$$

Now the equation cannot be satisfied by positive numbers so one of the ΔV 's must be negative. This is alright, the algebra will sort it out in the end.

Now consider starting at the lower right corner and taking the shortest clockwise loop. We pass through elements 5, 3, 2, and 4.

$$\Delta V_5 + \Delta V_3 - \Delta V_2 - \Delta V_4 = 0$$

Notice which ones are positive and which are negative.

We could also do the big loop, starting at the lower left and going clockwise through elements 1, 2, 4, and 5.

$$-\Delta V_1 - \Delta V_2 - \Delta V_4 + \Delta V_5 = 0$$

It is important to notice that this last equation could have been arrived at by combining the first two equations, so it has not really given us any new information. In general it does not help to write down more loop equations than there are “windows” in the circuit.

§ 3.6 Resistors in Combination

In a circuit where the same current runs through two resistors, those resistors are said to be *in series*. If we a circuit where the same electric potential is across two resistors, those resistors are said to be *in*

parallel. The diagram below will help explain why these configurations are named in this way.

Suppose that we have two resistors in series. Since they are in series they must carry the same current.

$$I_1 = I_2 = I$$

We also know that the potential difference across the pair is the sum of the potential differences across each individual resistor;

$$\begin{aligned}\Delta V &= \Delta V_1 + \Delta V_2 \\ &= I_1 R_1 + I_2 R_2 \\ &= I R_1 + I R_2 \\ &= I(R_1 + R_2)\end{aligned}$$

$$\longrightarrow R_{\text{effective}} = R_1 + R_2$$

We see that the pair of resistors in series still follow Ohm's law, and that the pair act as a single resistor with an effective resistance of $R_{\text{effective}} = R_1 + R_2$.

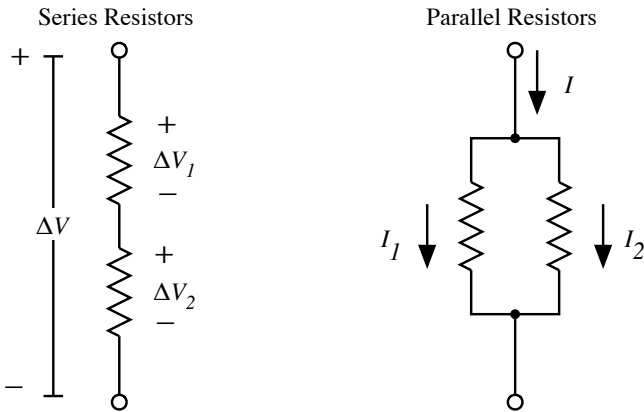

Now consider two resistors in parallel. Since they are in parallel they must have the same electric potential.

$$\Delta V_1 = \Delta V_2 = \Delta V$$

We also know from the junction rule that the net current going into the system is equal to the sum of the two currents going into the resistors.

$$\begin{aligned}I &= I_1 + I_2 = \frac{\Delta V_1}{R_1} + \frac{\Delta V_2}{R_2} = \frac{\Delta V}{R_1} + \frac{\Delta V}{R_2} \\ &= \Delta V \left[\frac{1}{R_1} + \frac{1}{R_2} \right]\end{aligned}$$

$$\longrightarrow \frac{1}{R_{\text{effective}}} = \frac{1}{R_1} + \frac{1}{R_2}$$

Theorem: Effective Resistance

$$\begin{array}{l} \text{Series} \quad R = R_1 + R_2 \\ \text{Parallel} \quad \frac{1}{R} = \frac{1}{R_1} + \frac{1}{R_2} \end{array}$$

§ 3.7 Capacitors in Combination

Capacitors in series and parallel can also be treated as a single capacitor. The argument is much the same, but with charge rather than current.

Suppose that you have two capacitors in series. Then the charges on each must be the same.

$$Q_1 = Q_2 = Q$$

While the potential drop across the pair is the sum of the potential drop across each

$$\begin{aligned} \Delta V &= \Delta V_1 + \Delta V_2 \\ &= \frac{Q_1}{C_1} + \frac{Q_2}{C_2} = \frac{Q}{C_1} + \frac{Q}{C_2} \\ \rightarrow \frac{1}{C} &= \frac{\Delta V}{Q} = \frac{1}{C_1} + \frac{1}{C_2} \end{aligned}$$

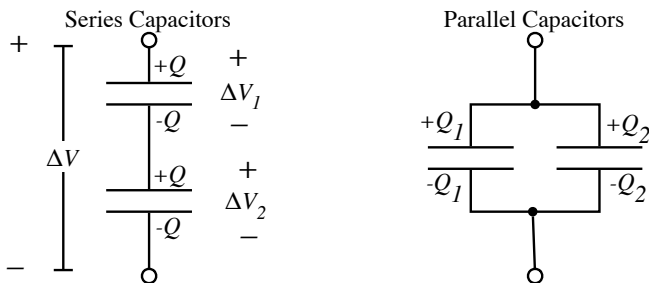

For capacitors in parallel the potential is the same.

$$\Delta V_1 = \Delta V_2 = \Delta V$$

While the net charge that flows into the system is shared between the capacitors.

$$\begin{aligned} Q &= Q_1 + Q_2 \\ &= C_1 \Delta V_1 + C_2 \Delta V_2 = C_1 \Delta V + C_2 \Delta V \\ \rightarrow C &= \frac{Q}{\Delta V} = C_1 + C_2 \end{aligned}$$

Theorem: Effective Capacitance

$$\text{Series } \frac{1}{C} = \frac{1}{C_1} + \frac{1}{C_2}$$

$$\text{Parallel } C = C_1 + C_2$$

§ 3.8 Capacitor Circuits

Consider the following circuit, which is composed of a power supply with a fixed electric potential output of V_S , a capacitor, a resistor, and a double pole switch.

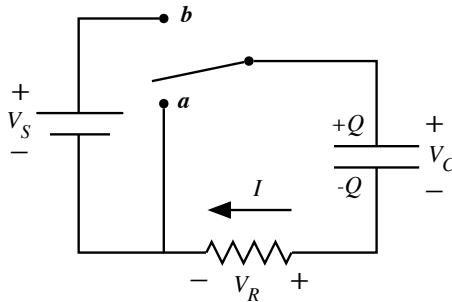

To begin with the switch is in position *a*. In this position all of the charge will drain from the capacitor. At the time $t = 0$ the switch is moved to position *b*. In this position the power supply will begin to fill the capacitor with charge. The current I flows into the capacitor. Thus the charge on the capacitor increases at the rate

$$\frac{dQ}{dt} = I$$

But for a capacitor the charge is proportional to the electric potential across the capacitor $Q = CV_C$ so that

$$I = \frac{dQ}{dt} = C \frac{dV_C}{dt}$$

Kirchhoff's loop rule gives us the following equation.

$$V_S - V_C - V_R = 0$$

But by Ohm's Law we have

$$V_R = RI = RC \frac{dV_C}{dt}$$

Putting this into the loop rule equation we find

$$V_S - V_C - RC \frac{dV_C}{dt} = 0$$

This is a differential equation that describes how the voltage on the capacitor changes with time, similar to how $F = ma$ is a differential equation that describes how a particles position changes with time. In this particular case we can find the solution by noting that if we define a new variable, $f(t) = V_C - V_S$ then $\frac{df}{dt} = \frac{dV_C}{dt}$ since V_S is a constant. Plugging this into our differential equation we find

$$-f - RC \frac{df}{dt} = 0$$

or

$$\frac{df}{dt} = -\frac{1}{RC}f$$

This just says that the derivative of f is simply a constant times f . The only function that has this property is the exponential. So let us try a function of the form

$$f = Ae^{\alpha t} \longrightarrow \frac{df}{dt} = \alpha Ae^{\alpha t} = \alpha f$$

Comparing this with our differential equation we see that it is the same if

$$\alpha = -\frac{1}{RC}$$

Thus

$$V_C - V_S = f = Ae^{-t/RC} \longrightarrow V_C = V_S + Ae^{-t/RC}$$

In order to determine the constant A we need to use the initial condition of the system. At $t = 0$ we know that there was no charge on the capacitor, thus the electric potential on the capacitor was zero at $t = 0$. Putting this into the solution we find that

$$0 = V_C(0) = V_S + Ae^{-0/RC} = V_S + A \longrightarrow A = -V_S$$

So the voltage on the capacitor is

$$V_C = V_S(1 - e^{-t/RC})$$

The combination RC is called the time constant of the circuit because it has units of time and gives the time scale for the change in the voltage: in a time RC the difference of the electric potential from it's final value (V_S) decreases by a factor of $e^{-1} \approx 3/8$.

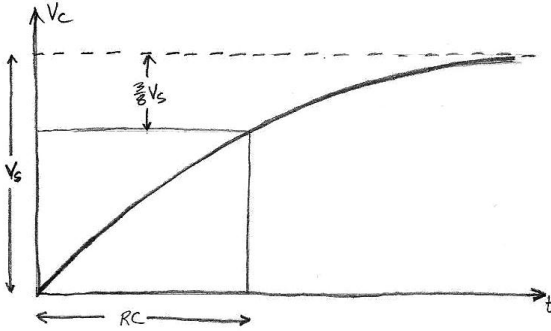

Note that the equation for V_C does not depend on R or C separately, but only on the combination RC .

▷ PROBLEM 3.6

Suppose that the capacitor circuit described above is assembled with a 10 Volt power supply, a $5.0\text{k}\Omega$ resistor, and a $3.0\mu\text{F}$ capacitor. How long after the switch is put in position b , will it be before the capacitor is half charged (5.0V)?

▷ PROBLEM 3.7

Assume that the capacitor circuit described above is left with the switch in position b for a long time, so that the capacitor is fully charged to the voltage V_S . The switch is now moved to position a . Show that $V_C = V_S e^{-t/RC}$.

§ 3.9 More Examples

EXAMPLE

The largest part of the nerve cells in your body is called the “axon.” The axon is in the shape of a cylinder and has sections through which ions pass, sending electrical signals through the nerve. During a nerve impulse, for the cylindrical section of an axon indicated below, 10,000 sodium ions (Na^+) pass through the surface of the cell membrane in 1 m/s. What is the current and current density into the cell?

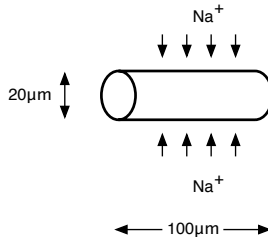

Each sodium ion has a charge $+1.6 \times 10^{-19} \text{C}$, so for 10,000 ions, $\Delta Q = 10,000 \times (1.6 \times 10^{-19} \text{C}) = 1.6 \times 10^{-15} \text{C}$. Since it takes 1ms:

$$I = \frac{\Delta Q}{\Delta t} = \frac{1.6 \times 10^{-15} \text{C}}{.001 \text{s}} = 1 \times 10^{-12} \text{A} = 1 \text{pA}.$$

The ions flow through the sides of the cylinder, so the magnitude of the current density is

$$J = \frac{I}{S} = \frac{1.6 \times 10^{-12} \text{A}}{(2\pi)(10\mu\text{m})(500\mu\text{m})} = 5.1 \times 10^{-5} \frac{\text{A}}{\text{m}^2} = 51 \frac{\mu\text{A}}{\text{m}^2}$$

EXAMPLE

A copper wire, with a diameter of 1mm, has a current of 5A flowing through it. What is the electric field in the wire?

Comment: How can $E \neq 0$? Earlier it was stated that $E = 0$ inside a conductor, however this was for the case of electrostatics. In the case of a current flowing, since electric charges are not static, the electric field will be nonzero.

For our wire, the current density is

$$J = \frac{I}{A} = \frac{5 \text{A}}{\pi(0.0005 \text{m})^2} = 6.4 \times 10^6 \frac{\text{A}}{\text{m}^2}$$

From Ohm's law:

$$J = \frac{1}{\rho} E$$

$$\begin{aligned} \longrightarrow E &= \rho J = (1.7 \times 10^{-8} \Omega\text{m})(6.4 \times 10^6 \frac{\text{A}}{\text{m}^2}) \\ &= 0.11 \frac{\Omega \cdot \text{A}}{\text{m}} = 0.11 \frac{\text{V}}{\text{m}} \end{aligned}$$

EXAMPLE

A light bulb with a resistance of 3Ω is connected to a 9V battery. In one second how many electrons flow through the bulb?

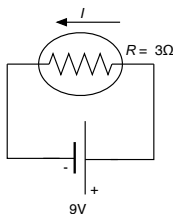

Use Ohm's law to find the current:

$$I = \frac{\Delta V}{R} = \frac{9 \text{V}}{3\Omega} = 3 \text{A}$$

This means that in one second, 3C of charge flows through the resistor. Since each electron (which will flow in a direction opposite the conventional positive current) carries $1.6 \times 10^{-19}\text{C}$ of charge:

$$N = \frac{3\text{A}}{1.6 \times 10^{-19}\text{C}} \times (1\text{s}) = 1.9 \times 10^{16}\text{electrons}$$

EXAMPLE

A 20W light bulb is left on in your car's interior. If the car's 12V battery is fully charged and has a capacity of 200Amp-hours. How long will it take to completely discharge the battery (assuming the terminal voltage remains 12V throughout the discharge)?

Use electric power P to compute the current that flows:

$$P = I\Delta V \longrightarrow I = \frac{P}{\Delta V} = \frac{20\text{W}}{12\text{V}} = 1.67\text{A}$$

The amount of charge that will pass through the bulb in a time Δt is $\Delta Q = 1.67\text{A} \times \Delta t$. The 200 Amp-hour rating tells us how much charge can pass from the positive terminal to the negative terminal of the battery before discharging the battery, so

$$\Delta Q 200\text{Ahr} = (1.67\text{A})\Delta t$$

$$\longrightarrow \Delta t = \frac{200\text{Ahr}}{1.67\text{A}} = 120\text{hr} = 5\text{days}$$

How much charge has flowed?

$$200\text{Ahr} = 200\text{A}(3600\text{s}) = (200\frac{\text{C}}{\text{s}})(3600\text{s}) = 720,000\text{C}$$

EXAMPLE

Determine the currents in the three resistors of the following circuit:

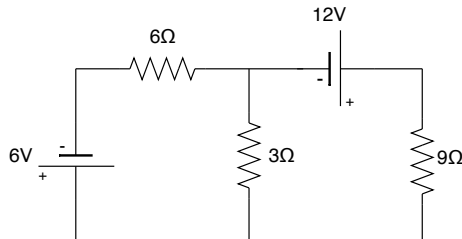

Let's label the currents. We will do our best to indicate the correct directions of the current:

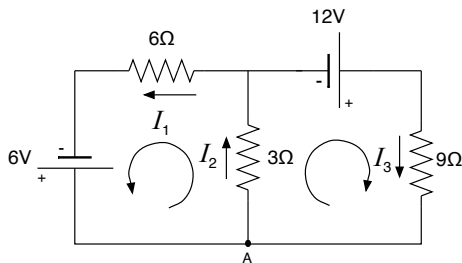

We now apply the loop rules to the two loops indicated. In both cases, start from the point labeled *A*, moving in the direction indicated, summing the potential gains or losses across each circuit element. For batteries the potential increases from the negative to the positive terminal. For resistors the current flows from high to low potential. Applying the loop rules gives two equations, one for each loop:

$$\begin{aligned} -(3\Omega)I_2 - (6\Omega)I_1 + 6V &= 0 \\ -(3\Omega)I_2 + 12V - (9\Omega)I_3 &= 0 \end{aligned}$$

We also must apply current conservation. Choose the point labeled *A*:

$$I_1 - I_2 + I_3 = 0$$

Now we have 3 equations with three unknowns. Solving the linear set of equations yields:

$$\begin{aligned} I_1 &= 0.364\text{A} \\ I_2 &= 1.27\text{A} \\ I_3 &= 0.91\text{A} \end{aligned}$$

Check that these are correct by putting them back into the loop equations:

$$\begin{aligned} -(3\Omega)(1.27\text{A}) - (6\Omega)(0.364\text{A}) + 6 &\longrightarrow -6.0\text{V} + 6.0\text{V} = 0 \\ -(3\Omega)(1.27\text{A}) + 12 - (9\Omega)(0.91\text{A}) &\longrightarrow -12.0\text{V} + 12.0\text{V} = 0 \end{aligned}$$

Determine the currents in the resistors of the following circuit:

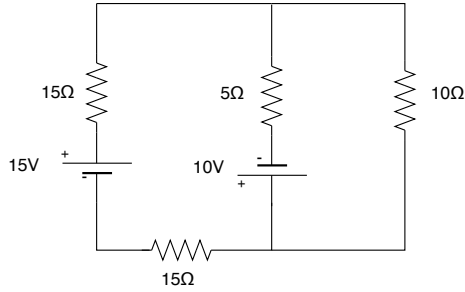

Label the currents, including best guesses for the directions:

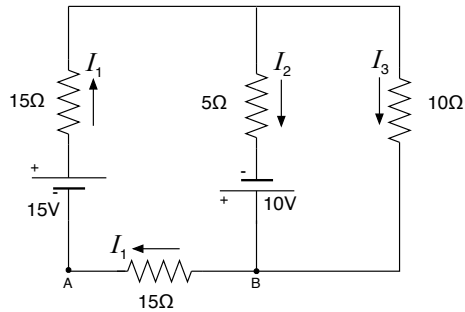

Apply Kirchoff's loop rules. First to the lefthand loop, beginning at point A and moving clockwise:

$$15\text{V} - (15\Omega)I_1 - (5\Omega)I_2 + 10\text{V} - (15\Omega)I_1 = 0,$$

then to the righthand loop, beginning at point B and moving counter-clockwise:

$$(10\Omega)I_3 - (5\Omega)I_2 + 10\text{V} = 0.$$

Note that for a resistor, the conventional positive current flows from high to low potential, which determines the sign to use when moving from one side of a resistor to the other.

Now apply Kirchoff's junction rule at the point labeled B :

$$I_2 + I_3 - I_1 = 0$$

Simplifying, we have three equations with three unknowns:

$$25 - 30I_1 - 5I_2 = 0$$

$$10 + 10I_3 - 5I_2 = 0$$

$$I_2 + I_3 - I_1 = 0$$

To solve, let first eliminate I_3 :

$$10 + 10I_3 - 5I_2 = 10 + 10(I_1 - I_2) - 5I_2 = 0$$

$$\longrightarrow 10 + 10I_1 - 15I_2 = 0$$

Next multiply the first equation, of the three listed above, by -3:

$$\longrightarrow -75 + 90I_1 + 15I_2 = 0.$$

Add the two modified equations together:

$$10 + 10I_1 - 15I_2 - 75 + 90I_1 + 15I_2 = 0$$

$$\longrightarrow -65 + 100I_1 = 0$$

$$\longrightarrow I_1 = .65\text{A}$$

Using this value of I_1 , we can solve for I_2 and I_3 :

$$I_2 = 1.1\text{A}$$

$$I_3 = -0.45\text{A}$$

The negative value obtained for I_3 indicates that the direction for this current is opposite the direction that was chosen. So I_3 flows up through the 10Ω resistor, not down as indicated in our diagram.

⊙ Do THIS NOW 3.1

Repeat the analysis for the circuit in the previous example, using the current directions shown below:

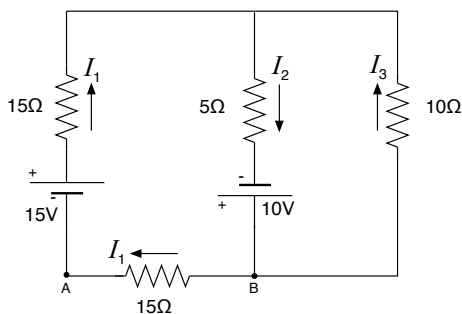

You should not get any negative-valued currents.

EXAMPLE

What is the effective resistance between the points A and B for the following circuit.

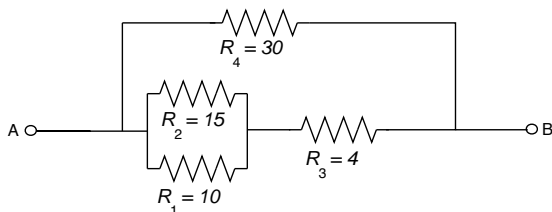

First combine R_1 and R_2 . Since they are in parallel:

$$\frac{1}{R_{12}} = \frac{1}{R_1} + \frac{1}{R_2} = \frac{1}{10\Omega} + \frac{1}{15\Omega} \longrightarrow R_{12} = 6\Omega$$

The circuit has been reduced to:

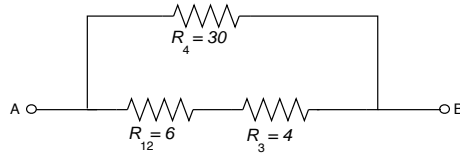

Now combine R_{12} and R_3 , which are in series:

$$R_{123} = R_{12} + R_3 = 6\Omega + 4\Omega = 10\Omega.$$

This leaves the effective circuit:

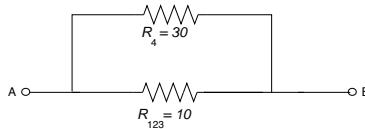

Finally, combine the last two resistances in parallel:

$$\frac{1}{R_{AB}} = \frac{1}{R_{123}} + \frac{1}{R_4} = \frac{1}{10\Omega} + \frac{1}{30\Omega} \longrightarrow R_{12} = 7.5\Omega$$

EXAMPLE

A 12V battery is connected across the points AB in the circuit from the previous example. What current flows through the $R_3 = 4\Omega$ resistor? First find the current that flows from A to B :

$$I_{AB} = \frac{V_{AB}}{R_{AB}} = \frac{12V}{7.5\Omega} = 1.6A$$

The incoming current splits between the 30Ω resistor and the effective resistance R_{123} :

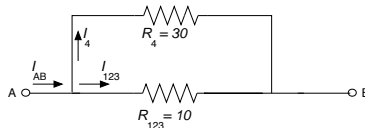

We can easily compute the current through the 30Ω resistor, since the potential difference across it is V_{AB} :

$$I_4 = \frac{V_{AB}}{R_4} = \frac{12V}{30\Omega} = 0.4A$$

Using Kirchoff's junction rule:

$$I_{123} = I_{AB} - I_4 = 1.6A - 0.4A = 1.2A.$$

Because the $R_3 = 4\Omega$ resistor is connected in series with the parallel combination of R_1 and R_2 , the current through it is I_{123} :

$$\longrightarrow I_3 = 1.2\text{A}$$

§ 3.10 Homework

▷ PROBLEM 3.8

In the Bohr model of the hydrogen atom, an electron in the lowest energy state follows a circular path, $5.29 \times 10^{-11}\text{m}$ from the proton. Show that the speed of the electron is $2.19 \times 10^6 \frac{\text{m}}{\text{s}}$. What is the effective current associated with this orbiting electron?

▷ PROBLEM 3.9

In a particular cathode ray tube, the measured beam current is $20\mu\text{A}$. How many electrons strike the tube screen every $\frac{1}{30}$ seconds?

▷ PROBLEM 3.10

The quantity of charge q (in coulombs) passing through a surface of area 2.0cm^2 varies with time as $q = 4t^3 + 5t + 6$ where t is in seconds. What is the instantaneous current through the surface at $t = 1.0\text{s}$? What is the value of the current density?

▷ PROBLEM 3.11

An electric current is given by $I(t) = 100.0 \sin(120\pi t)$, where I is in amperes and t is in seconds. What is the total charge carried by the current from $t = 0$ to $t = 1/240\text{s}$?

▷ PROBLEM 3.12

Calculate the average drift speed of electrons traveling through a copper wire with a cross-sectional area of 1.00mm^2 when carrying a current of 1.00A . It is known that about one electron per atom of copper contributes to the current. The atomic weight of copper is 63.54 and its density is 8.92g/cm^3 .

▷ PROBLEM 3.13

Eighteen gauge wire has a diameter of 1.024mm . Calculate the resistance of 15.0m of 18-gauge copper wire at 20.0°C .

▷ PROBLEM 3.14

Suppose that a voltage surge produces 140V for a moment. By what percentage will the output of a 120V , 100W lightbulb increase, assuming its resistance does not change?

▷ PROBLEM 3.15

Two cylindrical copper wires have the same mass. Wire A is twice as long as wire B . What is the ratio of their resistances?

▷ PROBLEM 3.16

Batteries are rated in ampere hours ($A \cdot \text{hr}$), where a battery rated at $1.0A \cdot \text{hr}$ can produce a current of $1.0A$ for 1.0hr .

(a) What is the total energy stored in a $12.0V$ battery rated at $55.0A \cdot \text{hr}$?

(b) At $\$0.12$ per kilowatt hour, what is the value of the electrical energy stored in this battery?

▷ PROBLEM 3.17

What is the required resistance of an immersion heater that will increase the temperature of a 1.5 kg of water from 10°C to 50°C in 10 min while operating at $110V$?

▷ PROBLEM 3.18

A battery with an emf of $12V$ and internal resistance of 0.90Ω is connected to a load resistor R .

(a) If the current in the circuit is $1.4A$, what is the value of R ?

(b) What power is dissipated in the internal resistance of the battery?

▷ PROBLEM 3.19

(a) Find the equivalent resistance between points a and b in the figure below.

(b) If a potential difference of $34V$ is applied between points a and b , calculate the current in each resistor.

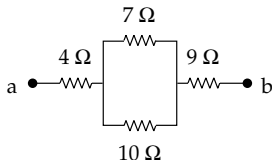

▷ PROBLEM 3.20

For the figure below find the current in the 20Ω resistor and the potential difference between points a and b .

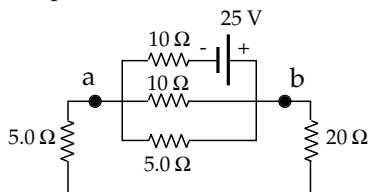

▷ PROBLEM 3.21

Determine the equivalent capacitance for the capacitor network shown below. If the network is connected to a $12V$ battery, calculate the potential difference across each capacitor and the charge on each capacitor.

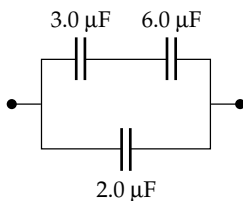

▷ PROBLEM 3.22

Four capacitors are connected as shown. Find the equivalent capacitance between points a and b . Calculate the charge on each capacitor in $V_{ab} = 15\text{V}$.

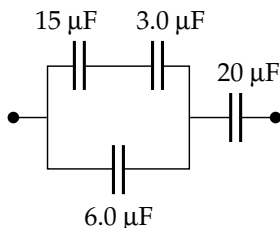

▷ PROBLEM 3.23

When two capacitors are connected in parallel, the equivalent capacitance is $4.00\mu\text{F}$. If the same capacitors are reconnected in series, the equivalent capacitance is one-fourth the capacitance of one of the two capacitors. Determine the two capacitances.

▷ PROBLEM 3.24

For the system of capacitors shown below find the equivalent capacitance of the system, the potential across each capacitor, the charge on each capacitor, and the total energy stored by the group.

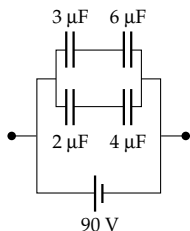

▷ PROBLEM 3.25

Calculate the equivalent capacitance between the two points shown in the circuit below. Note that this is not a simple series or parallel combination.

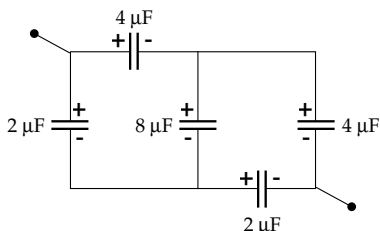

▷ PROBLEM 3.26

If $R = 1.0\text{k}\Omega$ and $\mathcal{E} = 250\text{V}$ determine the direction and magnitude of the current in the horizontal wire between a and e .

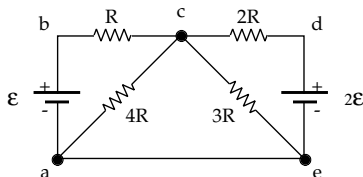

▷ PROBLEM 3.27

Determine the current in each branch of the figure.

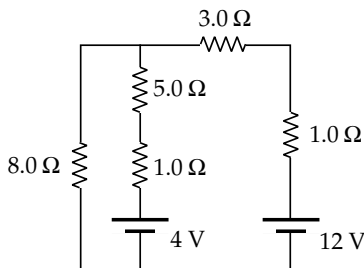

▷ PROBLEM 3.28

A 25-W light bulb is connected in series with a 100-W light bulb and a voltage V is placed across the combination. Which bulb is brighter? Explain.

▷ PROBLEM 3.29

An electric heater is rated at 1500W, a toaster at 750W, and an electric grill at 1000W. The three appliances are connected to a common 120V circuit. How much current does each draw? Is a 25A circuit sufficient in this situation?

▷ PROBLEM 3.30

An 8-foot extension cord has two 18-gauge copper wires, each having a diameter of 1.024mm. How much power does this cord dissipate when carrying a current of 1.0A? How much power does this cord dissipate when carrying a current of 10A?

▷ PROBLEM 3.31

Because aluminum has a greater resistivity than copper, aluminum wires heat up more than copper wires when they carry the same currents. For this reason aluminum wire of the same gauge (diameter) is rated to carry a smaller current. What current in an aluminum wire will heat up the wire the same amount as a copper wire of the same gauge carrying 20 Amps?

▷ PROBLEM 3.32

Consider the following circuit.

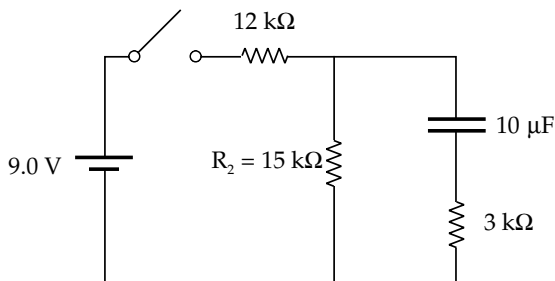

The switch is closed and the capacitor is allowed to charge up.

(a) How much charge will there be on the capacitor when it is fully charged?

(b) Now the switch is opened and the charge on the capacitor drains off. How long will it take for the capacitor to reach $1/5$ of the charge it had at the moment the switch was opened?

§ 3.11 Summary

Definitions

Electric Current:

$$I = \frac{dq}{dt}$$

Current Density

$$J = \frac{I}{A}$$

Facts

Ohm's Law: For many materials current density is proportional to the electric field.

$$\vec{J} = \sigma \vec{E}$$

with σ the conductivity of the material. $\rho = 1/\sigma$ is called the resistivity.

$$\Delta V = IR$$

with R the resistance of the device.

Theorems

Electric Power:

$$P = I\Delta V$$

Kirchhoff's Loop Rule:

$$\sum \Delta V = 0$$

Kierchhoff's Junction Rule:

$$\sum I_{\text{in}} = \sum I_{\text{out}}$$

Resistors in Parallel:

$$\frac{1}{R_{\text{eff}}} = \frac{1}{R_1} + \frac{1}{R_2}$$

Resistors in Series:

$$R_{\text{eff}} = R_1 + R_2$$

Capacitors in Parallel:

$$C_{\text{eff}} = C_1 + C_2$$

Capacitors in Series:

$$\frac{1}{C_{\text{eff}}} = \frac{1}{C_1} + \frac{1}{C_2}$$

4

Magnetic Fields

§ 4.1 Magnetic Field

We have all played with magnets at some point. Magnets will attract some types of metals and can attract and repel other magnets. This seems similar to electric forces. Magnetic forces can indeed be explained in terms of magnetic fields, but the connection between the magnetic field and the magnetic force is significantly different from that for electric fields and force. The magnetic field is similar to the electric field in that they are both vector fields. We use the symbol \vec{B} to represent the magnetic field. If we put a compass needle in a magnetic field, the field will turn the needle until it is aligned with the direction of the field. At this point we will use the following simple operational definition of the magnetic field. The direction of the magnetic field is the direction that a compass needle points. The magnitude of the magnetic field is related to how strong the force is that aligns the needle with the direction of the field.

A magnetic field does apply a force to charged particles. The magnetic force on the particle has the following properties:

- $F \propto q$
- $F \propto v$
- $F \propto B$
- \vec{F} is perpendicular to both \vec{v} and \vec{B} . These can be combined into the following succinct formula for the force.

Fact: Magnetic Force

A particle with charge q and velocity \vec{v} in a magnetic field \vec{B} will feel a force

$$\vec{F} = q \vec{v} \times \vec{B}$$

Notice that there is no force if the velocity is parallel to the magnetic field. Also notice that the magnetic force is **zero** on a stationary particle.

We can determine the dimensions of the magnetic field from the force equation:

$$F = qvB \longrightarrow B = \frac{F}{qv}$$

The unit of magnetic field is the *Tesla*, abbreviated as just T.

$$\text{Tesla} = \frac{\text{Newton}}{\text{Coulomb} \cdot \text{meter/second}} = \frac{\text{Kilogram}}{\text{Coulomb} \cdot \text{second}}$$

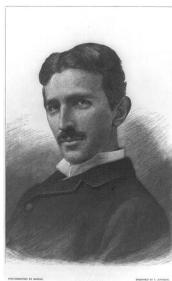

§ 4.2 Magnetic Force on a Current

If a current carrying wire is placed in a magnetic field it will experience a magnetic force. The current in the wire is composed of many moving charges. Each of these charges experiences a magnetic force. The force on the wire is the sum of the forces on all the moving charges in the wire.

Theorem: Magnetic Force on a Current

Suppose that you have a wire that is carrying a current I . A small section of wire of length $d\vec{\ell}$, where the vector points in the direction of the current, will experience a force

$$d\vec{F} = I d\vec{\ell} \times \vec{B}$$

The force on a longer section of wire can be found by integrating over the length of the section.

$$\vec{F} = \int I d\vec{\ell} \times \vec{B}$$

If the magnetic field is uniform over the region containing the wire then the following result can be proved.

Theorem: Force on a Current in a Uniform Field

Let $\vec{\Delta\ell}$ be a vector that points from the beginning to the end of a section of wire carrying a current I . If that section is in a uniform magnetic field, the force on that section is

$$\vec{F} = I \vec{\Delta\ell} \times \vec{B}$$

▷ PROBLEM 4.1

Consider a semicircular piece of wire of radius R in the first two quadrants of the x - y plane. The wire carries of current I in the counter-clockwise direction.

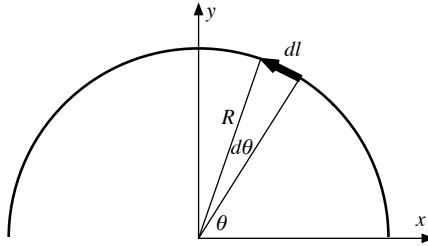

There is a uniform magnetic field in the y direction, $\vec{B} = B\hat{j}$. We wish to compute the net force on this section of wire without using the theorem $\vec{F} = I\vec{\Delta}\ell \times \vec{B}$.

(a) If we break the semicircle into small sections, they will be small sections of arc, as pictured in the diagram above. If we take one of these, it will be at a position θ , and will subtend an angle $d\theta$. Show that $d\vec{\ell} = (-\sin\theta\hat{i} + \cos\theta\hat{j})Rd\theta$

(b) With this result you can now compute the integral $\vec{F} = \int I d\vec{\ell} \times \vec{B}$. Show that the net force on the semicircle is $-I2RB\hat{k}$.

(c) Show that this is the same answer you get when you apply the theorem $\vec{F} = I\vec{\Delta}\ell \times \vec{B}$.

▷ PROBLEM 4.2

Consider the rectangular current loop pictured below.

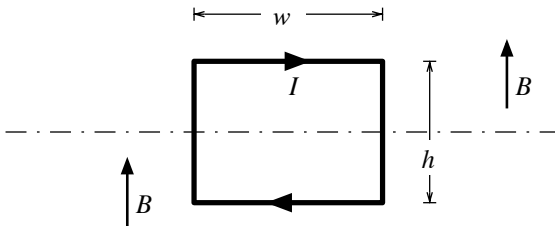

The field is uniform and in the direction indicated in the diagram. Show that the torque about the axis indicated by the dotted line is IAB where A is the area of the loop.

§ 4.3 Trajectories Under Magnetic Forces

Because the magnetic force is perpendicular to the velocity of the particle, the magnetic force can not do work on the particle. Suppose that a particle moves a small distance $d\vec{r}$. The work done by a force \vec{F} as the particle moves is

$$dW = \vec{F} \cdot d\vec{r}$$

But $d\vec{r} = \vec{v} dt$ so

$$dW = \vec{F} \cdot \vec{v} dt$$

For a magnetic force, \vec{v} and \vec{F} are perpendicular so that $\vec{F} \cdot \vec{v} = 0$. Thus $dW = 0$ for a magnetic force.

Theorem: Work by Magnetic Force

The magnetic force does zero work. Thus the magnetic force can change the direction but not the speed of a particle.

Because the magnetic force changes only the direction of a particle, a magnetic field is useful for steering charged particles, once they are already moving.

Consider a particle that is in a region with a uniform magnetic field. Suppose that the particles initial velocity is perpendicular to the magnetic field. Since the magnetic force is always perpendicular to the direction of the magnetic field, the force will have no component parallel to the field. So, since the particle started with zero velocity parallel to the field it will continue to have zero velocity parallel to the field. But this means that the velocity will always be perpendicular to the magnetic field, so $|\vec{v} \times \vec{B}| = vB$. Thus we know that the magnitude of the magnetic force is

$$F \equiv |\vec{F}| = q|\vec{v} \times \vec{B}| = qvB$$

In addition we know by the previous theorem that the speed of the particle will be constant, $v = v_0$. So that the magnitude of the force is constant. In summary, we see that the magnitude of the magnetic force on the particle is constant and perpendicular to the velocity, so that the acceleration of the particle is constant and perpendicular to the velocity. We have run into this situation before: In circular motion the acceleration is constant and always perpendicular to the velocity. We are lead by this observation to the following theorem.

Theorem: Circular Trajectories

If a particle is in a region of uniform magnetic field and entered the region with a velocity perpendicular to the magnetic field, then the particle will execute circular motion while in the region.

One can relate the radius and velocity of the motion to the field strength and charge by employing Newton's second law.

$$\begin{aligned} F &= ma \\ \longrightarrow qvB &= m \frac{v^2}{r} \end{aligned}$$

▷ PROBLEM 4.3

One can use the circular motion of a charge particle to determine it's mass if you already know it's charge. Suppose that you send a particle

with a charge $1.6 \times 10^{-19}\text{C}$ into a field 0.11mT with a speed of $3.83 \times 10^5 \frac{\text{m}}{\text{s}}$. The radius of the resulting motion is 2cm . What is the mass of the particle?

▷ PROBLEM 4.4

A stream of charged particles enter a circular region of uniform magnetic field as shown (gray). The particles fan-out in the region and each particle exits along one of the six trajectories A through F. Pick the trajectories for particles with the following properties:

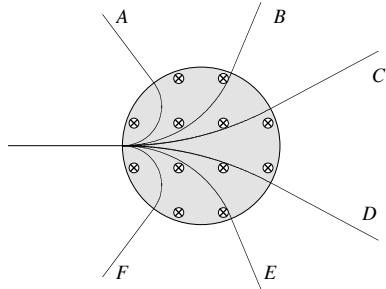

- Which particles are positively charged?
- If all the particles have the same mass and charge, which have the highest speed?
- If all the particles have the same speed and charge, which have the highest mass?
- If all the particles have the same mass and speed, which have the highest charge?

▷ PROBLEM 4.5

A particle is moving in a circular trajectory because of a magnetic field. Show that regardless of the velocity of the particle, it will take the same amount of time to complete one revolution. The fact that the time is a constant eased the development of the *cyclotron*, an early particle accelerator.

§ 4.4 Lorentz Force

If there is a magnetic as well as electric field then both forces act on a charge particle at the same time.

Definition: **Lorentz Force**

The combined electric and magnetic forces on a charge particle is called the *Lorentz Force*.

$$\vec{F} = q(\vec{E} + \vec{v} \times \vec{B})$$

▷ PROBLEM 4.6

There is a region with a uniform magnetic field $\vec{B} = B\hat{k}$ and electric field $\vec{E} = E\hat{j}$. Particles with charge q are sent into this region with a velocity $\vec{v} = v\hat{i}$.

- (a) Show that if $v = E/B$ that the particles will go straight through the region without deflection.
- (b) Show that if $v > E/B$ and $q > 0$ then the particles will be deflected in the negative y direction.
- (c) Show that if $v > E/B$ and $q < 0$ then the particles will be deflected in the positive y direction.
- (d) Show that if $v < E/B$ and $q > 0$ then the particles will be deflected in the positive y direction.

A device setup with crossed magnetic and electric fields as in the previous problem is called a *velocity selector*. Since it sorts out the particles based on their speeds, if you select out just the ones that go straight ahead, you have selected particles with a particular speed $v = E/B$. By adjusting the field strengths you can choose what velocity you would like to select.

§ 4.5 Hall Effect

Let us look with more detail at the flow of current in a wire that is in a magnetic field. Suppose that we have a rectangular conductor with a current I running through it.

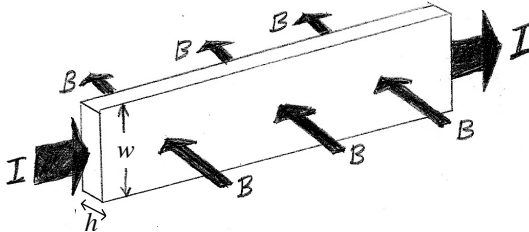

If we consider the charges in the wire we see that there will be a magnetic force on the particles that will tend to deflect them to one face of the conductor.

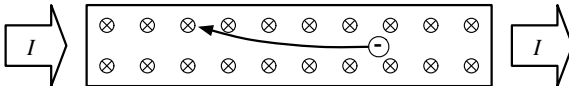

But this force will be acting on all the free charges, so they will all shift upward as they move through the conductor. Keeping in mind that the positive charge in the conductor does not move, we see that this shift of the (negative) free charges will build up a net negative charge on one face of the conductor and net positive charge on the opposing face.

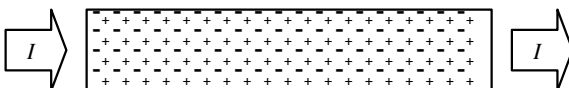

But this charge separation will create an electric field, that is in the opposite direction to the magnetic force, thus the charge will continue to build up on the face of the conductor until the electric field builds up to the point where the electric force on the charges balances the magnetic force on the charges.

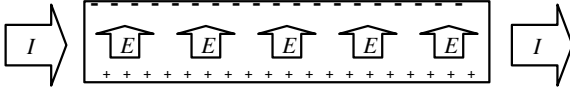

This will happen any time that a current carrying wire is in a magnetic field: the wire will spontaneously generate an electric field **across** the wire (not end to end but across). This effect, discovered by Edwin Hall, is called the *Hall Effect*. Because there is an electric field across the conductor there will also be an electric potential difference (called the Hall voltage), $\Delta V = Ew$ where w is the width of the conductor. But we know that in order for the electric force to cancel the magnetic force, we need $E = vB$. So we see that

$$\Delta V = vBw \longrightarrow v = \frac{\Delta V}{Bw}$$

Because it is relatively easy to measure the electric potential difference, the width of the conductor and the magnetic field strength, this type of device can be used to measure the velocity of the charge carriers. Knowing the velocity allows one to determine how many charge carriers there are per volume. In a time dt a quantity of charge $dq = I dt$ passes out the end of the wire, and a number of electrons $dn = dq/e = I dt/e$ passes out of the wire. But we can also say that the charges have moved a distance $dx = v dt$ in this time, so that a section of charge $v dt$ long has passed out of the wire. Thus a volume of charge $dV = hw v dt$ has passed out of the wire (where h is the thickness of the wire and hw is the cross sectional area of the wire). So the number of conduction electrons per volume (η) is

$$\eta = \frac{dn}{dV} = \frac{I dt/e}{hw v dt} = \frac{I}{ehw v}$$

The carrier density, η , depends on the type of material, not on the geometry of the material or the amount of current flowing through the material.

The Hall effect can be used to make a magnetic field sensor. By using the equation $v = \frac{\Delta V}{Bw}$ to eliminate the velocity from the equation $\eta = \frac{I}{ehw v}$, and then solving for B we find that

$$B = e\eta h \frac{\Delta V}{I}$$

The e , η and h are all constants for a given device, while ΔV and I are

both easily measured.

The Hall effect also allows us to determine if the charge carriers are positive or negative. In the analysis above we assumed that the charge carriers were negatively charged electrons. Consider what would happen if the charge carriers were positive instead. The positive charges would also be deflected by the magnetic field.

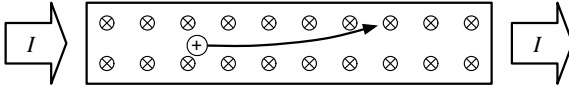

Which will build up a field in the opposite direction.

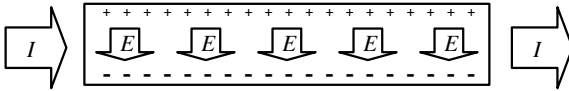

Thus we can determine from the sign of the Hall voltage, if the charge carriers are positive or negative. There are some types of semiconductors that have positive charge carriers, for example silicon with a little bit of aluminum mixed in. Semiconductors with positive charge carriers are called *p-type* semiconductors. Semiconductors with negative charge carriers are called *n-type* semiconductors.

§ 4.6 More Examples

EXAMPLE

An electron is injected horizontally into a parallel plate capacitor with a velocity $v = 4 \times 10^6 \frac{m}{s}$:

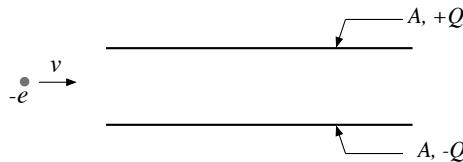

The plates are square, with sides 20cm and the charge on the capacitor is $7.5\mu C$. Describe what magnetic field is required such that the net force on the electron is zero between the capacitor plates. Ignore any edge effects.

The electric field points down, since the top plate on the capacitor is positive. However, since the electron has a negative charge, the electric force is up. Thus, the force caused by the magnetic field must be down. Here is what the force diagram on the electron must look like

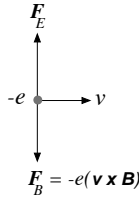

Again, since the electron’s charge is negative, the magnetic force will point in the direction opposite the cross-product $\vec{v} \times \vec{B}$. So, \vec{B} must point into the page. The magnitude of B can be determined since the net force is to be zero:

$$F_B = F_E$$

$$\rightarrow evB = eE$$

Or, solving for B :

$$B = \frac{E}{v}$$

For a parallel plate capacitor: $E = \sigma/\epsilon_0$, so

$$B = \frac{\sigma}{\epsilon_0 v} = \frac{Q}{\epsilon_0 v A}$$

$$\rightarrow B = \frac{7.5 \times 10^{-6} \text{C}}{(0.2\text{m})^2 (8.85 \times 10^{-12} \frac{\text{C}^2}{\text{Nm}^2}) (4 \times 10^6 \frac{\text{m}}{\text{s}})} = 5.3\text{T}$$

So, \vec{B} must be perpendicular to the electric field, pointing into the page with a magnitude of 5.3T for the electron to have no net force on it.

EXAMPLE

A proton is injected from a region with no magnetic field into a region with a strip of uniform magnetic field that is 10cm wide:

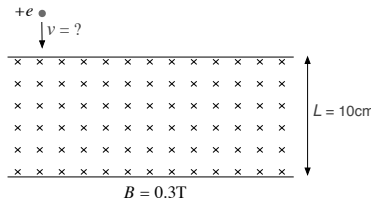

The magnetic field points into the page and has a magnitude of 0.3T. What is the maximum velocity the proton can have such that it does not make it across the 10cm magnetic-field region and exit through the other side?

Upon entering the magnetic field, the proton will experience a force perpendicular the velocity, which will cause it to follow a circular path:

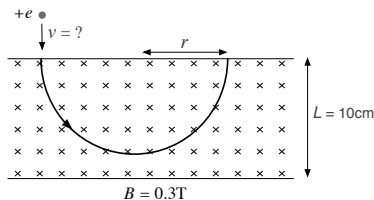

Let's compute the radius of the path in terms of the velocity. Newton's second law applied to the proton yields

$$F_B = m \frac{v^2}{r}$$

$$evB = m \frac{v^2}{r}$$

$$\rightarrow r = \frac{mv}{eB}$$

So as v increases so does r . In order that the proton not exit through the other side of the magnetic field region we must have $r < L$;

$$\frac{mv}{eB} < L$$

$$\rightarrow v < \frac{eBL}{m} = 2.9 \times 10^6 \frac{\text{m}}{\text{s}}$$

EXAMPLE A straight section of wire that is 0.5m long and carrying a current of $I = 8\text{A}$ directed along the $+x$ axis. One end of the wire is at the origin. The wire is in a magnetic field

$$\vec{B} = \hat{j} \left(3 \frac{\text{T}}{\text{m}^2} \right) x^2 + \hat{k} \left(2 \frac{\text{T}}{\text{m}} \right) x.$$

What is the force on the wire?

Look at a small section of the wire:

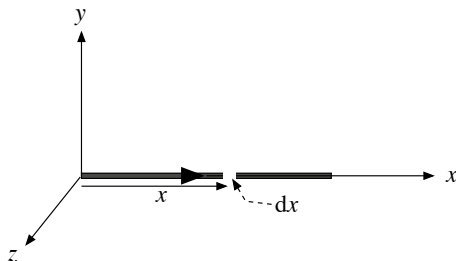

The force on this small section is:

$$\begin{aligned} d\vec{F} &= Id\vec{x} \times \vec{B} \\ &= (Idx)\hat{i} \times \left(\hat{j} \left(3\frac{\text{T}}{\text{m}^2} \right) x^2 + \hat{k} \left(2\frac{\text{T}}{\text{m}} \right) x \right) \\ &= (Idx) \left(\hat{k}(3x^2) - \hat{j}(2x) \right) \end{aligned}$$

Integrate over the entire length of the wire to get the total force:

$$\begin{aligned} \vec{F} &= \int_0^{0.5\text{m}} (Idx) \left(\hat{k}(3x^2) - \hat{j}(2x) \right) \\ &= I \left[\hat{i}(x^3) - \hat{j}(x^2) \right]_0^{0.5\text{m}} \\ &= (8\text{A}) \left[(0.5)^3 \hat{i} - (0.5)^2 \hat{j} \right] [\text{T} \cdot \text{m}] \\ &= (1\text{N})\hat{i} - (2\text{N})\hat{j} \end{aligned}$$

EXAMPLE

An L-shaped section of wire, carries a current I , and is in a constant magnetic field, as shown in the figure:

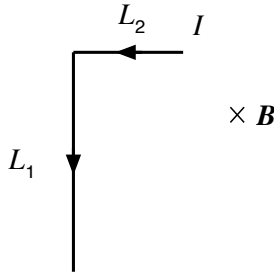

In terms of the parameters shown, what is the direction and magnitude of the net magnetic force on the wire?

Use the right hand rule to find the direction of the force on each segment:

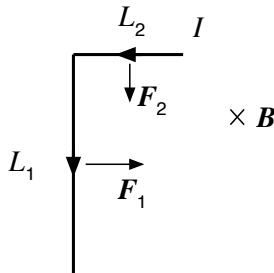

The net force is

$$\begin{aligned}\vec{F} &= \hat{i}F_1 - \hat{j}F_2 \\ &= \hat{i}IL_1B - \hat{j}IL_2B\end{aligned}$$

So the direction is given by

$$\theta = \tan^{-1} \left(\frac{IL_2B}{IL_1B} \right) = \tan^{-1} \left(\frac{L_2}{L_1} \right),$$

where θ is below the x -axis. The magnitude of the force is

$$F = \sqrt{F_1^2 + F_2^2} = IB\sqrt{L_1^2 + L_2^2}$$

EXAMPLE What is the net force on an $a \times b$ rectangular loop of wire carrying a current I that is in a uniform magnetic field perpendicular to the loop's plane?

Assume a direction for the magnetic field and use the right hand rule to draw the forces on each segment of the loop:

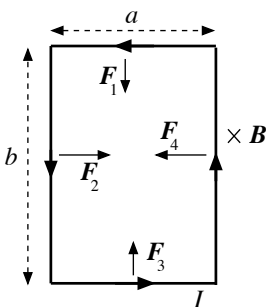

The net force on the loop is:

$$\begin{aligned}\vec{F} &= \vec{F}_1 + \vec{F}_2 + \vec{F}_3 + \vec{F}_4 \\ &= \hat{i}(F_2 - F_4) + \hat{j}(F_3 - F_1) \\ &= \hat{i}(IbB - IbB) + \hat{j}(IaB - IaB) \\ &= 0\end{aligned}$$

EXAMPLE Show that the magnetic force due to a uniform magnetic field for any closed current loop is zero.

The force law states

$$\vec{F} = I \oint d\vec{l} \times \vec{B}$$

Imagine the closed loop to be divided up into many $d\vec{l}_i$, approximated by a many-sided polygon:

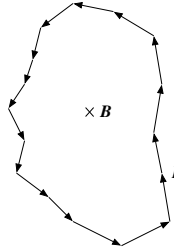

So, the integral is just the limit of a sum over all of the small segments:

$$\begin{aligned}\oint d\vec{l} \times \vec{B} &= d\vec{l}_1 \times \vec{B} + d\vec{l}_2 \times \vec{B} + \dots \\ &= (d\vec{l}_1 + d\vec{l}_2 + \dots) \times \vec{B} \\ &= \left(\oint d\vec{l} \right) \times \vec{B}\end{aligned}$$

\vec{B} is outside the integral because it is constant. The vector sum indicated by the integral in the last line must vanish since the vectors form a close polygon; graphical vector addition yields zero. Thus,

$$\begin{aligned}\vec{F} &= I \oint d\vec{l} \times \vec{B} \\ &= I \left(\oint d\vec{l} \right) \times \vec{B} \\ &= 0\end{aligned}$$

§ 4.7 Homework

▷ PROBLEM 4.7

Consider an electron near the equator. In which direction does it tend to deflect by the magnetic field of the earth if its velocity is directed (a) downward, (b) northward, (c) westward, or (d) southeastward?

▷ PROBLEM 4.8

An electron moving along the positive x axis perpendicular to a magnetic field experiences a magnetic deflection in the negative y direction. What is the direction of the magnetic field?

▷ PROBLEM 4.9

An electron in a uniform electric and magnetic field has a velocity of $1.2 \times 10^4 \frac{\text{m}}{\text{s}}$ in the positive x direction and an acceleration of $2.0 \times 10^{12} \frac{\text{m}}{\text{s}^2}$

in the positive z direction. If the electric field has a strength of 20N/C in the positive z direction, what is the magnetic field in the region?

▷ PROBLEM 4.10

A duck flying due north at $15\frac{\text{m}}{\text{s}}$ passes over Atlanta, where the Earth's magnetic field is $5.0 \times 10^{-5}\text{T}$ in a direction 60° below the horizontal line running north and south. If the duck has a net positive charge of $0.040\mu\text{C}$, what is the magnetic force acting on it?

▷ PROBLEM 4.11

A proton moves with a velocity of $v = (2\hat{i} - 4\hat{j} + \hat{k})\frac{\text{m}}{\text{s}}$ in a region in which the magnetic field is $\vec{B} = (\hat{i} + 2\hat{j} - 3\hat{k})\text{T}$. What is the magnitude of the magnetic force this charge experiences?

▷ PROBLEM 4.12

Show that the work done by the magnetic force on a charged particle moving in a magnetic field is zero for any displacement of the particle.

▷ PROBLEM 4.13

Below is shown a cube (40cm on each edge) in a magnetic field with a wire carrying a current $I = 5.0\text{A}$ over the surface of the cube. If there is a magnetic field $\vec{B} = 0.020\text{T}\hat{j}$. What is the magnitude and direction of the magnetic force on each straight segment of the current loop?

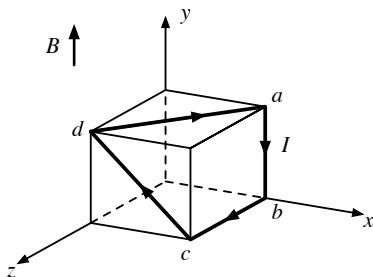

▷ PROBLEM 4.14

A singly charged positive ion has a mass of $3.20 \times 10^{-26}\text{kg}$. After being accelerated through a potential difference of 833V , the ion enters a magnetic field of 0.920T along a direction perpendicular to the direction of the field. Calculate the radius of the path of the ion in the field.

Find the velocity of the particle first then use the circular motion result.

▷ PROBLEM 4.15

A proton (charge $+e$, mass m_p), a deuteron (charge $+e$, mass $2m_p$), and an alpha particle, (charge $+2e$, mass $4m_p$) are accelerated through a common potential difference, V . The particles enter a uniform magnetic field B , in a direction perpendicular to B . The particles move in

circular orbits. Write the radii of the orbits of the deuteron, r_d , and the alpha particle, r_α , in terms of the radius of the protons orbit r_p .

▷ PROBLEM 4.16

Indicate the initial direction of the deflection of the charged particles as they enter the magnetic fields shown below.

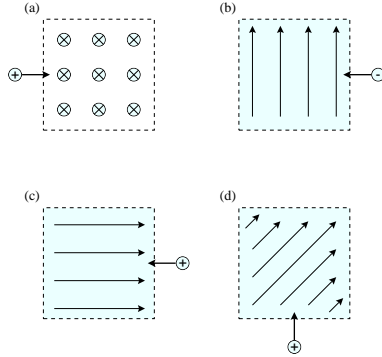

▷ PROBLEM 4.17

A proton moves through a uniform electric field $\vec{E} = 50\hat{j}\text{V/m}$ and a uniform magnetic field $\vec{B} = (0.20\hat{i} + 0.30\hat{j} + 0.40\hat{k})\text{T}$. Determine the acceleration of the proton when it has a velocity $\vec{v} = 200\hat{i}\frac{\text{m}}{\text{s}}$.

§ 4.8 Summary

Definitions**Facts**

Force on a moving charge:

$$\vec{F} = q\vec{v} \times \vec{B}$$

Force on a piece of wire carrying a current I :

$$d\vec{F} = I d\vec{\ell} \times \vec{B}$$

Theorems

5

Sources of Magnetic Field

§ 5.1 Sources of Magnetic Field

So far we have not considered how magnetic fields are created. As you may know it is possible to create an *electromagnet* by wrapping a wire around a nail and running a current through the wire. The precise way in which a current produces a magnetic field is captured in the following law.

Fact: Biot-Savart Law

If you have a wire carrying a current I , a small section of the wire $d\vec{\ell}$ will produce a magnetic field

$$d\vec{B} = \frac{\mu_0 I}{4\pi} \frac{d\vec{\ell} \times \hat{r}}{r^2}$$

where \vec{r} is the vector that points from the location of the element $d\vec{\ell}$ to the field point. The total field is the sum of the contributions of each element of the wire.

This may look complicated but it represents the simple fact that the magnetic field wraps around the wire, and decreases in strength as you move away. In the figure below is depicted two magnetic field lines that are due to the current element $d\vec{\ell}$ indicated.

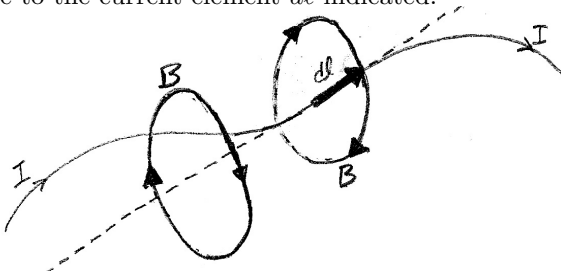

Note that the field warps around the extension of the current element in circles. This figure does not depict how the field strength changes with position. The direction the field wraps around the current is the same direction the fingers of your right hand will wrap around the wire if you grasp the wire with your thumb pointing in the direction of the current.

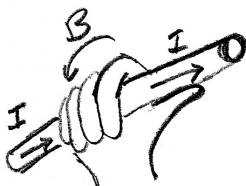

In order to apply the Biot-Savart law one must first *parameterize* the curve that the wire follows. A parameterization for a curve is a vector function $\vec{r}(t)$ of one variable t , such that $\vec{r}(t)$ points from the origin to the curve and sweeps along the curve as the variable t is increased. Below is picture such a vector function at the values of t .

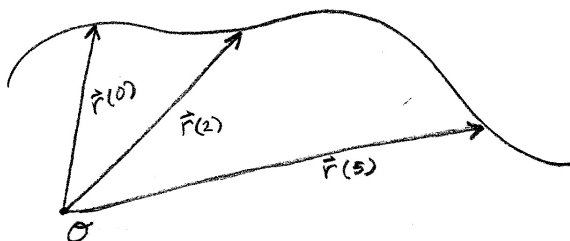

The variable t is not the time, but it is sometimes helpful to think of it as the time, so that you can imagine $\vec{r}(t)$ is the position of some particle that is following the curve.

As an example consider the following vector function of t .

$$\vec{r}(t) = a \cos t \hat{i} + a \sin t \hat{j}$$

This is a parameterization of a circle of radius a centered at the origin. There are other parameterizations of a circle. For example $\vec{r}(t) = a \cos t \hat{i} - a \sin t \hat{j}$ is also a parameterization of a circle, but as t increases the vector sweeps clockwise rather than counterclockwise.

▷ PROBLEM 5.1

For the parameterization of a circle $\vec{r}(t) = a \cos t \hat{i} + a \sin t \hat{j}$, over what range would you need to vary t in order to have the vector sweep over the quarter circle in the second quadrant?

Here are some other parameterizations.

Straight Line : $\vec{r}(t) = at\hat{i} + bt\hat{j} + c\hat{k}$

Helix : $\vec{r}(t) = a \cos t \hat{i} + a \sin t \hat{j} + bt\hat{k}$

Spiral : $\vec{r}(t) = t \cos t \hat{i} + t \sin t \hat{j}$

Vertical Parabola : $\vec{r}(t) = \vec{a} + bt\hat{i} + ct^2\hat{j}$

Horizontal Parabola : $\vec{r}(t) = \vec{a} + bt^2\hat{i} + ct\hat{j}$

▷ PROBLEM 5.2

Write a parameterization for a parabola that goes through the three points $(-1,0)$, $(0,1)$ and $(1,0)$.

With the parameterization in hand we can proceed with a computation using the Biot-Savart law. First we notice that if we change t a little bit dt that the difference between $\vec{r}(t)$ and $\vec{r}(t+dt)$ is a short vector along the curve.

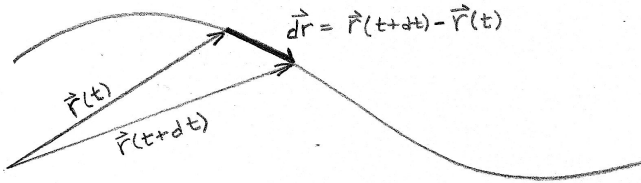

So we see that the small section along the curve $d\vec{\ell}$ that appears in the Biot-Savart law can be found from our parameterization. Further since

$$d\vec{r} = \vec{r}(t+dt) - \vec{r}(t) = \frac{\vec{r}(t+dt) - \vec{r}(t)}{dt} dt = \frac{d\vec{r}}{dt} dt$$

we can write

$$d\vec{\ell} = \frac{d\vec{r}}{dt} dt$$

This was the main point of the parameterization, now we can “add up” the contributions from all the sections by integrating over the parameter t .

We still need to do another step before we can write out the integral. We need to write out the vector that points from the current element $d\vec{\ell}$ to the field point. So that we do not get the different vectors mixed up, let us call the vector that points from the origin to the field point \vec{r}_f , and let us call the parameterization of the current path $\vec{r}_s(t)$. Then the vector that points from the current element to the field point can be written as

$$\vec{r} = \vec{r}_f - \vec{r}_s(t)$$

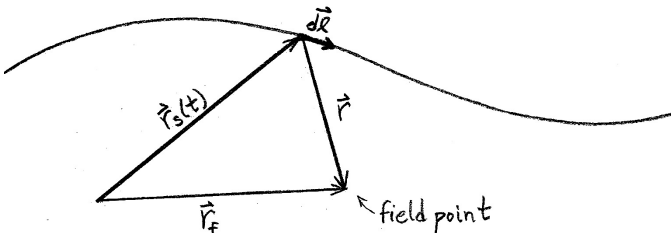

Now we can write out the Biot-Savart integral in terms of the parameterization.

$$\begin{aligned}\vec{B}(r_f) &= \frac{\mu_0 I}{4\pi} \int \frac{d\vec{\ell} \times \hat{r}}{r^2} \\ &= \frac{\mu_0 I}{4\pi} \int \frac{d\vec{\ell} \times \vec{r}}{r^3} \\ &= \frac{\mu_0 I}{4\pi} \int \frac{d\vec{r}_s}{dt} \times [\vec{r}_f - \vec{r}_s(t)]}{|\vec{r}_f - \vec{r}_s(t)|^3} dt\end{aligned}$$

This gives us a system by which we can find the field at any point due to any current that we can parameterize. Of course it is very rare that the integral has an analytic solution, but one can use a computer to evaluate the integral numerically once you have used this system to write out the integral.

In order to see exactly what all this means let us do an example.

EXAMPLE

Suppose that we have a current of 15 amps going through a section of wire that follows the curve below, which has the following parameterization.

$$\vec{r}_s(t) = (-t + t^3)\hat{i} + t^2\hat{j}$$

Where the distance is in meters, and t goes from -0.9 to 0.9.

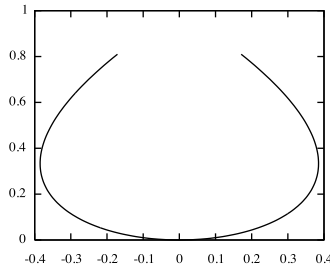

We want to find the field at the point $\vec{r}_f = 0\hat{i} + 1\hat{j}$. In preparation for plugging into the Biot-Savart law we compute the following quantities.

$$\vec{r}_f - \vec{r}_s(t) = (t - t^3)\hat{i} + (1 - t^2)\hat{j} = (1 - t^2)(t\hat{i} + \hat{j})$$

$$|\vec{r}_f - \vec{r}_s(t)|^2 = (1 - t^2)^2(t^2 + 1)$$

$$|\vec{r}_f - \vec{r}_s(t)|^3 = (1 - t^2)^3(t^2 + 1)^{3/2}$$

and

$$\frac{d\vec{r}_s}{dt} = (-1 + 3t^2)\hat{i} + 2t\hat{j}$$

and

$$\begin{aligned} \frac{d\vec{r}_s}{dt} \times [\vec{r}_f - \vec{r}_s(t)] &= [(-1 + 3t^2)\hat{i} + 2t\hat{j}] \times [(1 - t^2)(t\hat{i} + 1\hat{j})] \\ &= (1 - t^2) [(-1 + 3t^2)\hat{i} + 2t\hat{j}] \times [(t\hat{i} + 1\hat{j})] \\ &= (1 - t^2) [(-1 + 3t^2) - 2t^2] \hat{k} \\ &= -(1 - t^2)^2 \hat{k} \end{aligned}$$

Now putting this into the parameterized form of the Biot-Savart law we find:

$$\begin{aligned} \vec{B}(\vec{r}_f) &= \frac{\mu_0 I}{4\pi} \int \frac{\frac{d\vec{r}_s}{dt} \times [\vec{r}_f - \vec{r}_s(t)]}{|\vec{r}_f - \vec{r}_s(t)|^3} dt \\ &= \frac{\mu_0 I}{4\pi} \int_{-0.9}^{0.9} \frac{-(1 - t^2)^2 \hat{k}}{(1 - t^2)^3 (t^2 + 1)^{3/2}} dt \\ &= -\frac{\mu_0 I}{4\pi} \hat{k} \int_{-0.9}^{0.9} \frac{1}{(1 - t^2)(t^2 + 1)^{3/2}} dt \\ &= -\frac{\mu_0 I}{4\pi} \hat{k} [1.9367\text{m}^{-1}] \\ &= -(2.90\text{mT})\hat{k} \end{aligned}$$

▷ PROBLEM 5.3

Consider a straight section of wire along the x -axis that goes from $x = a$ to the $x = b$. The wire carries a current I . What is the magnetic field at the position $\vec{r}_f = y\hat{j}$.

▷ PROBLEM 5.4

A circular section of wire is carrying a current I counterclockwise. The arc of the wire subtends an angle of θ . The circle has a radius a . What is the magnetic field due to this section of wire at the center of the circle?

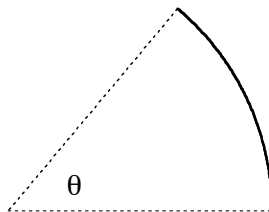

§ 5.2 Ampere's Law

In addition to the Biot-Savart law, there is another way of stating the relationship between a current and the magnetic field it produces.

Fact: Ampere's Law

For any closed curve the line integral of the magnetic field around the curve is equal to the μ_0 times the net current through the surface enclosed by the curve.

$$\oint \vec{B} \cdot d\vec{\ell} = \mu_0 I_{\text{through}} = \mu_0 \int \vec{J} \cdot d\vec{A}$$

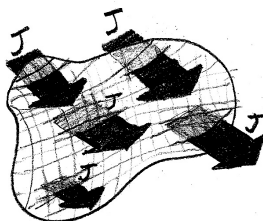

It is not at all apparent that Ampere's law is equivalent to the Biot-Savart law, but it is. One can prove the Biot-Savart law from Ampere's Law and visa versa. While they are mathematically equivalent, they are useful in different situations. Ampere's law is useful for abstract reasoning about fields, and for finding the field strength in highly symmetric configurations.

It is important when applying Ampere's law to keep in mind that the amperian loop does not correspond to anything physical. There does not need to be anything there in order for the law to work. You are free to choose the amperian loop to be any shape you like. Of course, as was the case with applying Gauss's law, if you want to use the law to find the field strength you need to pick the loop correctly. In order to use Ampere's Law to find the field strength, you need three things from the loop.

- The loop must pass through the point at which you want to find the field strength and be parallel to the field at that point.
- The loop must be either parallel or perpendicular to the field at all points on the loop.
- In all regions where the loop is parallel to the field, the field must have the same strength.

EXAMPLE Ampere's law can be used to find the field strength a distance r from a long straight wire. We will take our loop to be a circle that wraps around the wire and has a radius r .

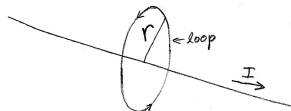

This satisfies all three of the above requirements. Since the loop is parallel to the field at all points on the loop,

$$\vec{B} \cdot d\vec{\ell} = B dl$$

and since B has the same value at all points on the loop,

$$\int B dl = B \int dl = B 2\pi r$$

But by Ampere's Law this must also be equal to $\mu_0 I$. Thus

$$B 2\pi r = \mu_0 I \quad \rightarrow \quad B = \frac{\mu_0 I}{2\pi r}$$

EXAMPLE

In the previous example we found the magnetic field outside of a long wire. Now let us find the magnetic field that is inside the wire itself. The method is much the same. We choose our loop to be a circle of radius r that wraps around the central axis of the wire, which we has a radius R . Since we want to find the field inside the wire we will be working with $r < R$. We still find the same results that $B = \frac{\mu_0 I}{2\pi r}$, but we must remember the current in this equation is the current that goes through our loop. This current is not the full current of the wire, since our loop does not enclose the entire wire. So we need to find the current through our loop of radius r . Let us assume that the current density in the wire is uniform. Then we can say that the total current in the wire is $I = J\pi R^2$ and the current through the loop is $I_{\text{through}} = J\pi r^2$. Combining these two equations to eliminate J we find that

$$I_{\text{through}} = \frac{r^2}{R^2} I.$$

So that

$$B = \frac{\mu_0 I_{\text{through}}}{2\pi r} = \frac{\mu_0 I}{2\pi R^2} r = \frac{\mu_0 I r}{2\pi R^2}$$

The following graph shows the magnetic field both inside and outside the conductor.

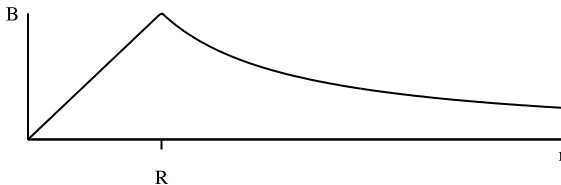

EXAMPLE

In this example we will see how to deal with a current density that is not uniform. Suppose that we have a long wire with a current density that is greater at the center and drops off to zero at the edge: $J(r) = \frac{3I}{\pi R^2}(1 - r/R)$. We want to find the magnetic field and from Ampere's law we find $B = \frac{\mu_0 I_{\text{through}}}{2\pi r}$. The difficulty is that since J is not uniform we cannot use $I = JA$ to find I_{through} . We need to use $dI = JdA$ to find $I_{\text{through}} = \int JdA$. This example will show how to do that.

We need to pick the area elements so that the current density is uniform over the entire surface of each element. Since the current density is a function of r only, J is constant in regions that are circles around the center. So we will use a circular element dA , as pictured in gray in the figure. The figure shows a cross section of the wire.

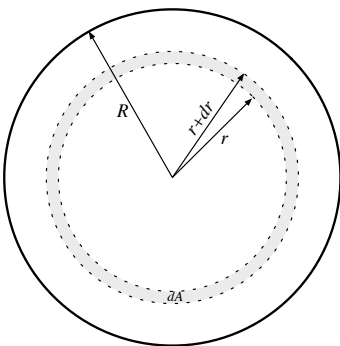

In the limit that dr is very small the area will be simply the length around the circular area element, $2\pi r$ times the width of the element dr so that $dA = 2\pi r dr$. Now we can compute the current inside a loop of radius r_{loop} by integrating.

$$\begin{aligned} I_{\text{through}} &= \int_0^{r_{\text{loop}}} J dA = \int_0^{r_{\text{loop}}} \frac{3I}{\pi R^2} (1 - r/R) 2\pi r dr \\ &= I \frac{r^2}{R^2} \left(3 - 2\frac{r}{R} \right) \\ \rightarrow B &= \frac{\mu_0 I_{\text{through}}}{2\pi r} = \frac{\mu_0 I r}{2\pi R^2} \left(3 - 2\frac{r}{R} \right) \end{aligned}$$

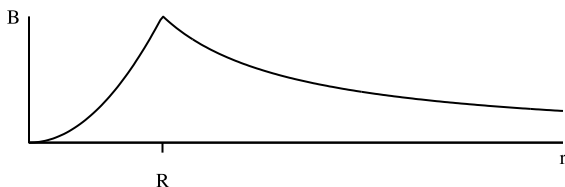

▷ PROBLEM 5.5

Consider a long wire where the current density is not uniform but instead increases as you approach the center of the wire, so that at a

distance r from the center the current density is $J(r) = \frac{I}{2\pi Rr}$. Note that this is not a very realistic current density but it is easy to work with. Find the magnetic field strength both inside and outside of this wire.

§ 5.3 Force Between Parallel Wires

Now that we know that the strength of the magnetic field produced by a long straight current carrying wire we can find the force between two parallel wires.

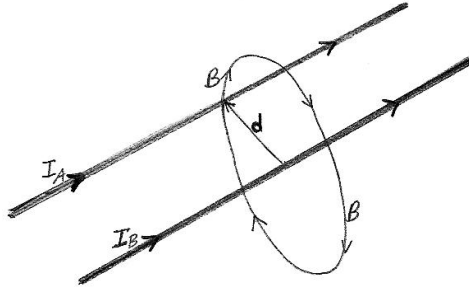

In the figure above the field produced by current B in the region of current A is shown. Using the right hand rule we can see that the direction of the force on wire A is toward wire B. We can also see that the field and the current are perpendicular so that the magnitude of the force on a length L of wire A is

$$F = I_A L B = I_A L \frac{\mu_0 I_B}{2\pi d} = \frac{\mu_0 I_A I_B L}{2\pi d}$$

where d is the distance between the wires.

Theorem: Force Currents

Two long parallel wires have a force per length between them of

$$\frac{F}{L} = \frac{\mu_0 I_A I_B}{2\pi d}$$

where d is the distance between the currents.

▷ PROBLEM 5.6

An electrical cable carries 45 amps in each of two wires that are a distance of 4mm apart. The currents are in opposites directions.

- Is the force between the wires attractive or repulsive?
- What is the force per length between the wires?

§ 5.4 More Examples

EXAMPLE Finite Wire

A straight wire of length a carries a current I . What is the magnetic field caused by the current at a point (x, y) measured from the center of the wire?

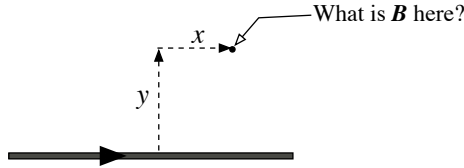

The wire is a straight line, which can be parametrized:

$$\vec{r}_s = (at)\hat{i},$$

where t varies from $-\frac{1}{2}$ to $+\frac{1}{2}$. So we have:

$$\frac{d\vec{r}_s}{dt} = a\hat{i}$$

We want to find the magnetic field at the position

$$\vec{r}_f = x\hat{i} + y\hat{j},$$

Collect the quantities needed for applying the Biot-Savart law:

$$\vec{r}_f - \vec{r}_s = (x - at)\hat{i} + y\hat{j}$$

$$|\vec{r}_f - \vec{r}_s| = \sqrt{(x - at)^2 + y^2}$$

$$\frac{d\vec{r}_s}{dt} \times (\vec{r}_f - \vec{r}_s) = (a\hat{i}) \times ((x - at)\hat{i} + y\hat{j})$$

$$= ay\hat{k}$$

Using the Biot-Savart law:

$$\begin{aligned} \vec{B}(x, y) &= \frac{\mu_0 I}{4\pi} \int \frac{\frac{d\vec{r}_s}{dt} \times [\vec{r}_f - \vec{r}_s]}{|\vec{r}_f - \vec{r}_s|^3} dt \\ &= \frac{\mu_0 I}{4\pi} \int_{-\frac{1}{2}}^{\frac{1}{2}} \frac{ay\hat{k}}{((x - at)^2 + y^2)^{\frac{3}{2}}} dt \\ &= -\frac{\mu_0 I y}{4\pi} \int_{x+\frac{a}{2}}^{x-\frac{a}{2}} \frac{du}{(u^2 + y^2)^{\frac{3}{2}}} \hat{k} \end{aligned}$$

where I have substituted $u = x - at$ into the last expression. Looking

up the integral:

$$\begin{aligned}\vec{B}(x, y) &= \frac{\mu_0 I y}{4\pi} \left[\frac{u}{y^2 \sqrt{u^2 + y^2}} \right]_{x - \frac{a}{2}}^{x + \frac{a}{2}} \hat{k} \\ &= \frac{\mu_0 I}{4\pi y} \left(\frac{x + \frac{a}{2}}{\sqrt{(x + \frac{a}{2})^2 + y^2}} - \frac{x - \frac{a}{2}}{\sqrt{(x - \frac{a}{2})^2 + y^2}} \right) \hat{k}\end{aligned}$$

The resulting expression gives the magnetic field anywhere in the plane we've chosen as the xy -plane. What about points that lie out of this plane? Let's rotate our diagram:

Looking from the side

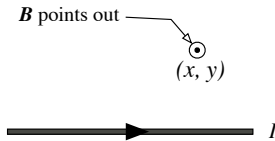

Looking down the wire

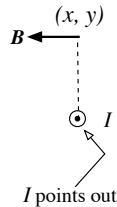

Now imagine rotating the xy plane around the wire. Since the distances x and y remain the same, only the direction of \hat{k} will change. The following diagram shows how the position of the magnetic field will change for different points, that are equidistant from the line:

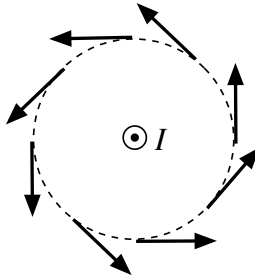

The magnetic field “rotates” around the wire. A quick method to determine which direction the rotation of the field goes is to use a modified right-hand rule: Stick your right thumb in the direction of the current and your fingers will point in the direction of the field's rotation.

distance r from an infinite wire was $\frac{\mu_0 I}{2\pi y}$. Let us take the limit of $a \rightarrow \infty$ of the results we have for the finite wire, and see if we get the same results.

$$\begin{aligned} B &= \lim_{a \rightarrow \infty} \frac{\mu_0 I}{4\pi y} \left(\frac{x + \frac{a}{2}}{\sqrt{(x + \frac{a}{2})^2 + y^2}} - \frac{x - \frac{a}{2}}{\sqrt{(x - \frac{a}{2})^2 + y^2}} \right) \\ &= \frac{\mu_0 I}{4\pi y} \left(\frac{\frac{a}{2}}{\sqrt{(\frac{a}{2})^2}} - \frac{-\frac{a}{2}}{\sqrt{(-\frac{a}{2})^2}} \right) = \frac{\mu_0 I}{2\pi y} \quad \text{OK} \end{aligned}$$

EXAMPLE

A circular wire with radius a carries a current I . Locate the circle in the xy -plane and compute the magnetic field it causes along a line through its center.

Here is the geometry of the loop:

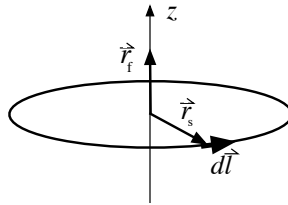

The path along the circle can be parameterized using $t = [0, 2\pi]$:

$$\begin{aligned} \vec{r}_s &= a \cos t \hat{i} + a \sin t \hat{j} \\ \frac{d\vec{r}_s}{dt} &= -a \sin t \hat{i} + a \cos t \hat{j} \end{aligned}$$

We also have

$$\begin{aligned} \vec{r}_f &= z \hat{k} \\ \vec{r}_f - \vec{r}_s &= -a \cos t \hat{i} - a \sin t \hat{j} + z \hat{k} \\ |\vec{r}_f - \vec{r}_s| &= \sqrt{a^2 \cos^2 t + a^2 \sin^2 t + z^2} \\ &= \sqrt{a^2 + z^2} \end{aligned}$$

Compute the cross product needed for the Biot-Savart law:

$$\begin{aligned} \frac{d\vec{r}_s}{dt} \times (\vec{r}_f - \vec{r}_s) &= (-a \sin t \hat{i} + a \cos t \hat{j}) \times (-a \cos t \hat{i} - a \sin t \hat{j} + z \hat{k}) \\ &= az \cos t \hat{i} + az \sin t \hat{j} + (a^2 \sin^2 t + a^2 \cos^2 t) \hat{k} \\ &= az \cos t \hat{i} + az \sin t \hat{j} + a^2 \hat{k} \end{aligned}$$

Use the Biot-Savart law:

$$\begin{aligned}\vec{B} &= \frac{\mu_0 I}{4\pi} \int \frac{d\vec{r}_s \times [\vec{r}_f - \vec{r}_s]}{|\vec{r}_f - \vec{r}_s|^3} dt \\ &= \frac{\mu_0 I}{4\pi} \int_0^{2\pi} \frac{az \cos t \hat{i} + az \sin t \hat{j} + a^2 \hat{k}}{(a^2 + z^2)^{\frac{3}{2}}} dt\end{aligned}$$

Since the integrals of the cosine and sine vanish for the interval $[0, 2\pi]$, the resulting magnetic field is:

$$\begin{aligned}\vec{B} &= \frac{\mu_0 I a^2}{4\pi (a^2 + z^2)^{\frac{3}{2}}} \hat{k} \int_0^{2\pi} dt \\ \rightarrow \vec{B} &= \frac{\mu_0 I}{2} \frac{a^2}{(a^2 + z^2)^{\frac{3}{2}}} \hat{k}\end{aligned}$$

EXAMPLE

A semi-circular shaped wire with radius a carries a current I . What is the magnetic field caused at the center of the semi-circle's diameter?

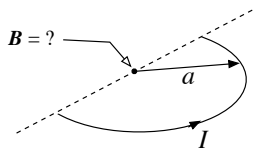

Divide the wire into small sections and compute the magnetic field contribution due to one small section:

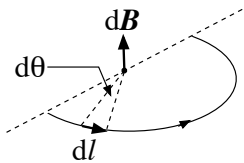

The direction for all sections is up, by the right hand rule. Use the Biot-Savart law for the magnitude:

$$\begin{aligned}d\vec{B} &= \frac{\mu_0}{4\pi} \frac{I d\vec{l} \times \vec{r}'}{r'^3} \hat{k} \\ &= \frac{I \mu_0}{4\pi} \frac{(dl)(a)}{a^3} \hat{k},\end{aligned}$$

since $d\vec{l}$ and the radius vector to the point are perpendicular. The length of dl can be approximated by the length of the arc subtended by the angle $\Delta\theta$, so

$$\begin{aligned} |d\vec{B}| &= \frac{I\mu_0}{4\pi} \frac{(ad\theta)(a)}{a^3}, \\ &= \frac{I\mu_0}{4\pi} \frac{d\theta}{a} \end{aligned}$$

To find the magnetic field due to the entire wire, integrate:

$$B = \frac{I\mu_0}{4\pi} \int_0^\pi \frac{d\theta}{a} = \frac{I\mu_0}{4a}$$

EXAMPLE

Two sections of straight wire carrying electric current lie parallel to each other, a distance b apart:

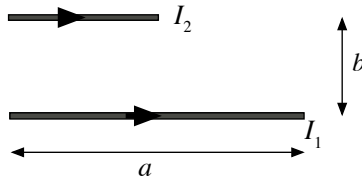

The leftmost ends of the wires are aligned. What is the force that current I_1 exerts on current I_2 ? Draw a coordinate system:

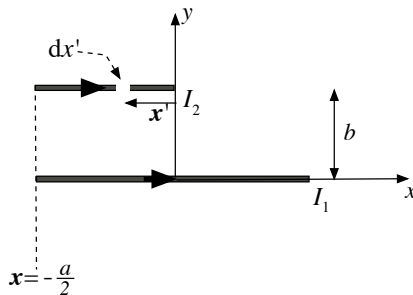

The z -axis points out of the page. From a previous example, we know that the magnetic field due to I_1 in the xy -plane is

$$\vec{B}_2(x, y) = \frac{\mu_0 I_1}{4\pi y} \left(\frac{x + \frac{a}{2}}{\sqrt{(x + \frac{a}{2})^2 + y^2}} - \frac{x - \frac{a}{2}}{\sqrt{(x - \frac{a}{2})^2 + y^2}} \right) \hat{k}$$

The magnetic force on the small segment, dx' indicated for I_2 is

$$\begin{aligned} d\vec{F}_{21} &= I_2(dx' \hat{i}) \times \vec{B}_2(x', b) \\ &= \frac{\mu_0 I_1 I_2}{4\pi b} (\hat{i} \times \hat{k}) \left(\frac{x' + \frac{a}{2}}{\sqrt{(x' + \frac{a}{2})^2 + b^2}} - \frac{x' - \frac{a}{2}}{\sqrt{(x' - \frac{a}{2})^2 + b^2}} \right) dx' \\ &= \frac{\mu_0 I_1 I_2}{4\pi b} (-\hat{j}) \left(\frac{x' + \frac{a}{2}}{\sqrt{(x' + \frac{a}{2})^2 + b^2}} - \frac{x' - \frac{a}{2}}{\sqrt{(x' - \frac{a}{2})^2 + b^2}} \right) dx' \end{aligned}$$

To compute the total force on I_2 , integrate over the length of the wire:

$$\vec{F}_{21} = -\hat{j} \frac{\mu_0 I_1 I_2}{4\pi b} \int_{-\frac{a}{2}}^0 \left(\frac{x' + \frac{a}{2}}{\sqrt{(x' + \frac{a}{2})^2 + b^2}} - \frac{x' - \frac{a}{2}}{\sqrt{(x' - \frac{a}{2})^2 + b^2}} \right) dx'$$

The integrals can be done using simple substitution, and yield:

$$\vec{F}_{21} = -\frac{\mu_0 I_1 I_2}{4\pi b} \left(\sqrt{a^2 + b^2} - b \right) \hat{j}$$

What is the force exerted on I_1 by I_2 ? Newton's third law gives us the answer:

$$\vec{F}_{12} = \frac{\mu_0 I_1 I_2}{4\pi b} \left(\sqrt{a^2 + b^2} - b \right) \hat{j}$$

Notice that the two wires attract each other. What would happen if one of the current's directions was reversed?

They would repel each other.

§ 5.5 Homework

▷ PROBLEM 5.7

Calculate the magnitude of the magnetic field at a point 100 cm from a long, thin conductor carrying a current of 1.0 A.

▷ PROBLEM 5.8

A wire in which there is a current of 5.00 A is to be formed into a circular loop of one turn. If the required value of the magnetic field at the center of the loop is $10.0\mu\text{T}$, what is the required radius?

▷ PROBLEM 5.9

In Neils Bohr's 1913 model of the hydrogen atom, an electron circles the proton at a distance of $5.3 \times 10^{-11}\text{m}$ with a speed of $2.2 \times 10^6 \frac{\text{m}}{\text{s}}$. Compute the magnetic field strength that this motion produces at the location of the proton.

▷ PROBLEM 5.10

Determine the magnetic field at a point P located a distance x from the corner of an infinitely long wire bent at a right angle, as shown. The wire carries a steady current I .

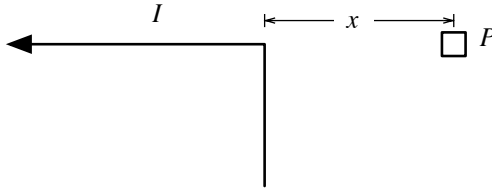

▷ PROBLEM 5.11

Consider the current-carrying loop shown below, formed of radial lines and segments of circles whose centers are at point P . Find the magnitude and direction of \vec{B} at P .

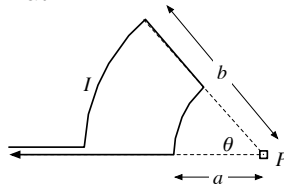

▷ PROBLEM 5.12

Two long, parallel conductors separated by 10.0 cm carry currents in the same direction. If $I_1 = 5.00\text{A}$ and $I_2 = 8.00\text{A}$, what is the force per unit length exerted on each conductor by the other?

▷ PROBLEM 5.13

Imagine a long cylindrical wire of radius R that has a current density $J(r) = J_0(1 - r^2/R^2)$ for $r \leq R$ and $J(r) = 0$ for $r > R$, where r is the distance from a point of interest to the central axis running along the length of the wire.

- Find the resulting magnetic field inside and outside the wire.
- Plot the magnitude of the magnetic field as a function of r .
- Find the location where the magnetic field strength is a maximum, and the value of the maximum field.

▷ PROBLEM 5.14

Below is shown a cross-sectional view of a coaxial cable. The center conductor is surrounded by a rubber layer, which is surrounded by an outer conductor, which is surrounded by another rubber layer. The current in the inner conductor is 1.00 A out of the page. The current in the outer conductor is 3.00 A into the page. Determine the magnitude and direction of the magnetic field at the points indicated at a distance 1mm and 3mm from the center.

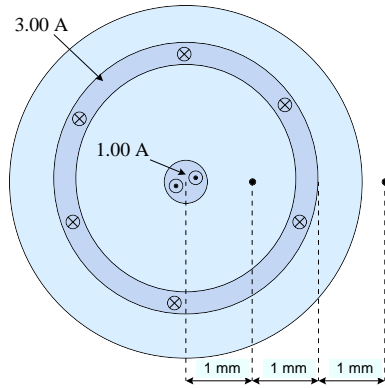

▷ PROBLEM 5.15

A long cylindrical conductor of radius R carries a current I . The current density J is not uniform over the cross-section of the conductor but is a function of the radius $J = br$, where b is a constant. find the magnetic field inside and outside the conductor.

§ 5.6 Summary

Definitions

Facts

Field due to a section of current:

$$d\vec{B} = \frac{\mu_0 I}{4\pi} \frac{d\vec{\ell} \times \hat{r}}{r^2}$$

Theorems

Ampere's Law:

$$\oint \vec{B} \cdot d\vec{\ell} = \mu_0 \int \vec{J} \cdot d\vec{A}$$

6

Time Varying Fields

§ 6.1 Introduction

Let us take a moment to review what we know about the means of producing electric and magnetic fields. We have found two means to produce fields.

- Electric fields are produced when there are regions in space with a net electric charge. This is encapsulated in Gauss's law.

$$\oint \vec{E} \cdot d\vec{A} = \frac{1}{\epsilon_0} \int \rho \, dV$$

- Magnetic fields are produced when there is a flow of charge. This is encapsulated in Ampere's law.

$$\oint \vec{B} \cdot d\vec{\ell} = \mu_0 \int \vec{J} \cdot d\vec{A}$$

So far, we have investigated only *steady state* fields (fields that don't change in time). A net electric charge and a steady flow of charge are the only means to produce steady state electric and magnetic fields. But these are not the only means of producing time varying fields. In this chapter we will investigate time varying electromagnetic systems.

§ 6.2 Faraday's Law

Let us start by considering what will happen if we have some source of time varying magnetic field. It could for example be a wire that is carrying a current and the current is changing rapidly in time. Since the current is changing in time, the magnetic field that the current creates will also change with time.

If we place a loop of wire into this time varying magnetic field, the time varying field will produce a current in the wire. This is called an induced current. Nikola Tesla was able to produce such strong induced currents that he was able to make a light bulb glow with the current. In the photo to the right Tesla is holding a light bulb which has no wires connected to it. The current driving the bulb is entirely an induced current, which is caused by the time varying magnetic field.

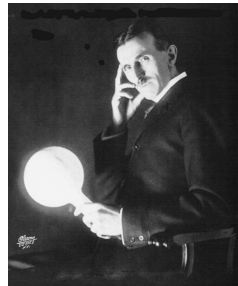

The induced current is caused by an electric field. This induced electric field is not like the other electric fields we have seen. This is a new type of electric field. The electric field is created by the changing magnetic field.

The electric field wraps around the changing magnetic field somewhat like a static magnetic field wraps around a steady current. There are some additional subtleties due to the fact that the induced electric field is caused by the change in the magnetic field. The relationship between the induced electric field and the changing magnetic field is stated in the following law of physics.

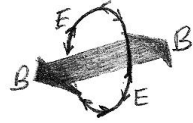

Fact: **Faraday's Law**

The line integral of the electric field around any closed curve is equal to negative the rate of change of the magnetic flux through any surface bounded by the curve.

$$\oint \vec{E} \cdot d\vec{\ell} = -\frac{d}{dt} \int \vec{B} \cdot d\vec{A}$$

Notice that this is very similar to Ampere's Law:

$$\oint \vec{B} \cdot d\vec{\ell} = \mu_0 \int \vec{J} \cdot d\vec{A}$$

Ampere's Law and Faraday's Law both relate the line integral around closed curve to the flux of a vector field through the area enclosed by the curve. The difference is that Faraday's Law has the time derivative of the flux.

Another important and potentially confusing thing to notice, is that the line integral of the electric field ($\int \vec{E} \cdot d\vec{\ell}$) has so far been referred to as the electric potential difference between the end points of the curve. The confusing thing is that since it is a closed curve the electric potential difference must be zero, $\Delta V = 0$, while Faraday's Law tells us that the line integral of the induced electric field is not zero, but equal to the rate of change of the magnetic flux. So we learn from this that the force caused by the **induced** electric field is **not** a conservative force field. We also see that there is no electric potential associated with this electric field, ($\vec{E} \neq -\vec{\nabla}V$). To avoid confusion we will refer to the line integral of the induced electric field by its historical name, the *electromotive force*, or *EMF*. In equations the EMF is represented by the symbol \mathcal{E} , so that $\mathcal{E} = \oint \vec{E} \cdot d\vec{\ell}$. Note that the unit of EMF is the volt.

Definition: Magnetic Flux

The integral of the magnetic field over the area of the loop is called the *magnetic flux*.

$$\phi_m = \int \vec{B} \cdot d\vec{A}$$

Note that this is of the same form as the definition of the electric flux ($\phi_e = \int \vec{E} \cdot d\vec{A}$), in addition you may have noticed that current is the flux of current density, ($I = \int \vec{J} \cdot d\vec{A}$). With the definition of magnetic flux and EMF we can rewrite Faraday's Law in a simpler looking form.

Theorem: Faraday's Law (alternate form)

The induced EMF in a loop is equal to the negative rate of change of the magnetic flux through the loop.

$$\mathcal{E} = -\frac{d\phi_m}{dt}$$

EXAMPLE

Suppose that we are in a region where the magnetic field is uniform and increasing with time:

$$\vec{B} = \vec{B}_0 + at\hat{i} + bt\hat{j} + ct\hat{k}.$$

We place a loop of wire with an area of A , so that it lies flat in the x - y plane. We want to compute the induced EMF in the loop. Since the loop is in the x - y plane we know that in computing the magnetic flux ($\int \vec{B} \cdot d\vec{A}$), that the area elements will all be pointing in the z direction: $d\vec{A} = \hat{k} dA$. So

$$\begin{aligned} \phi_m &= \int \vec{B} \cdot d\vec{A} = \int (\vec{B}_0 + at\hat{i} + bt\hat{j} + ct\hat{k}) \cdot \hat{k} dA \\ &= \int (B_{0z} + ct) dA = (B_{0z} + ct) \int dA = (B_{0z} + ct)A \end{aligned}$$

So we can compute the induced EMF in the loop.

$$\mathcal{E} = -\frac{d\phi_m}{dt} = -\frac{d}{dt}[(B_{0z} + ct)A] = -cA$$

What can we learn from this example? First we learn that **only** the component of the magnetic field that is normal to the surface of the loop contributes to the magnetic flux. Second we see that **no** component of the constant part of the field, \vec{B}_0 , contributes to the induced EMF, only the time varying part of the field induces an EMF.

EXAMPLE Consider now a field that is

$$\vec{B} = B_0 \cos \omega t \hat{k}$$

Again we take the loop in the x - y plane.

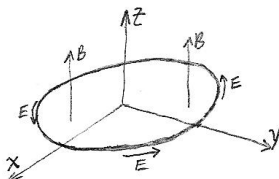

Because the field is uniform we again get the result that the flux is the product of the normal component of the field and the area of the loop.

$$\phi_m = B_0 A \cos \omega t$$

And thus that

$$\mathcal{E} = -\frac{d\phi_m}{dt} = B_0 A \omega \sin \omega t$$

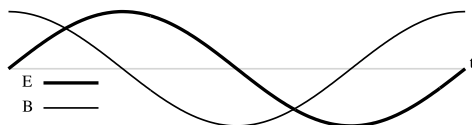

The previous example will be very helpful in understanding the relationship between the direction of the magnetic field and the direction of the induced electric field. As we said before the induced electric field wraps around the magnetic field, but we did not say in which direction it wraps itself. The above example will help us understand the direction.

First notice that in the figure above a positive magnetic field is one that is in the positive z direction, while a positive electric field is one that is counterclockwise. (This choice of positive directions is in compliance with another right hand rule, that we will express as Lenz's law in just a moment.) Now examine the graph of the electric and magnetic fields. Sometimes the fields have the same sign and sometimes they do not. Let us analyze the the graph in four quarters. In the first quarter notice that the electric field is counterclockwise, the magnetic field is positive, and the magnitude of the magnetic field is decreasing. This is represented in symbols in the first row of the table below. The other three quarters follow.

- First Quarter: $E \oplus$ and $B \uparrow$ and $|B| \searrow$.
- Second Quarter: $E \oplus$ and $B \downarrow$ and $|B| \nearrow$.

- Third Quarter: $E \ominus$ and $B \downarrow$ and $|B| \searrow$.
- Fourth Quarter: $E \ominus$ and $B \uparrow$ and $|B| \nearrow$.

Here are the same four quarters in diagrams:

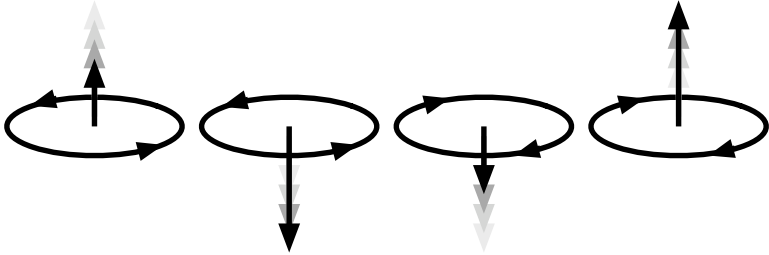

Notice that if the magnitude of the flux is decreasing, the fields have the same sign. While if the magnitude of the flux is increasing, the fields have opposite sign. This observation is usually stated in terms of the current that is caused by the induced electric field if a loop of wire is placed in line with the electric field loop.

Fact: Lenz's Law

The induced current creates a magnetic field that opposes the change in the magnetic flux.

▷ PROBLEM 6.1

Check to see that Lenz's law is obeyed in all four quarters in the previous example.

§ 6.3 Maxwell's Extension of Ampere's Law

We have seen that a changing magnetic field causes an electric field. It ends up that a changing electric field will also cause a magnetic field.

$$\oint \vec{B} \cdot d\vec{\ell} = \mu_0 \epsilon_0 \frac{d}{dt} \int \vec{E} \cdot d\vec{A}$$

This magnetic field is added to the magnetic field produced by currents so that we arrive at an extension of Ampere's law that makes it applicable to time varying fields.

Fact: Ampere's Law - Time Varying

$$\begin{aligned} \oint \vec{B} \cdot d\vec{\ell} &= \mu_0 \int \vec{J} \cdot d\vec{A} + \mu_0 \epsilon_0 \frac{d}{dt} \int \vec{E} \cdot d\vec{A} \\ &= \mu_0 I_{\text{through}} + \mu_0 \epsilon_0 \frac{d\phi_e}{dt} \end{aligned}$$

The quantity $\epsilon_0 \frac{d\phi_e}{dt}$ is sometimes called the *displacement current* because it acts like a current in Ampere's Law.

▷ PROBLEM 6.2

You have a parallel plate capacitor with circular plates. The capacitor is being charged so that the electric field between the plates is increasing at a constant rate: $E = at$, with $a = 4.5 \times 10^{10} \text{V} \cdot \text{m}^{-1} \text{s}^{-1}$. Use the extended version of Ampere's Law to find the magnetic field at a distance $r = 4.0 \text{cm}$ from the center of the capacitor and half way between the plates. Assume that the field is circular about the axis of the capacitor.

§ 6.4 Inductance

Suppose that you have a loop of wire in a region where there is no source of magnetic field. If you run a current through the wire there will now be a magnetic field due to the current. This magnetic field will create a magnetic flux through the loop. Because the field produced is proportional to the current, the flux will also be proportional to the current.

$$\phi_m = LI$$

The proportionality constant L is called the self *inductance* of the loop. The induced EMF on the loop is the product of the inductance and the rate of change of the current.

$$\mathcal{E} = L \frac{dI}{dt}$$

Circuit elements are manufactured with specific values of inductance, and are called inductors. The SI unit of inductance is called the *Henry*, abbreviated as H. Inductors are essentially a coil of wire, sometimes wrapped around a core of material designed to increase the inductance. The sign of \mathcal{E} has been chosen in such a way as to facilitate the application of Kirchhoff's loop rule to inductors. It is the same convention that was used for the resistor.



For an inductor Lenz's law can be interpreted as "the induced EMF across an inductor is in such a direction as to oppose the change in the current through the inductor". For example, suppose that a current is flowing through an inductor, if you now try and reduce the current, an EMF will be generated in the inductor that will tend to keep the current going. Similarly if you try to increase the current an EMF will be generated that will tend to stop the current from increasing.

EXAMPLE

Suppose that you have the circuit shown. By some means you have established a current in the circuit (perhaps it is an induced current caused by some external magnetic field) such that at $t = 0$ the current is I_0 . At $t = 0$ the external cause of the current disappears. What will happen to the current?

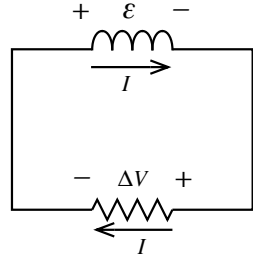

Since the inductor opposes the change in the current the current will not stop abruptly. Instead it will decrease gradually, the inductor will drive the circuit for a while. Note that this implies that an inductor can store energy, much like a capacitor can. Let us see how we would do the circuit analysis of this system.

Kirchhoff's Loop rule give us that

$$\begin{aligned}\mathcal{E} + \Delta V &= 0 \\ \rightarrow L \frac{dI}{dt} + IR &= 0 \\ \rightarrow \frac{dI}{dt} &= -\frac{R}{L}I \\ \rightarrow I(t) &= I_0 e^{-\frac{R}{L}t}\end{aligned}$$

Thus we see that the current will decay exponentially.

▷ PROBLEM 6.3

The circuit below is assembled with the switch open. At the time $t = 0$ the switch is closed.

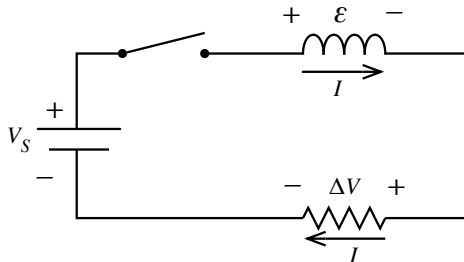

- What is the current as a function of time?
- What is the EMF as a function of time?
- What is the voltage on the resistor as a function of time?
- Check to see if Kirchhoff's loop rule is satisfied at all times.

(e) Sketch the graphs of all three functions.

§ 6.5 Alternating Current

Often the currents in a circuit are sinusoidal.

$$I(t) = I_0 \cos \omega t$$



A circuit with such a current is referred to as an *alternating current* circuit, or AC circuit, because the current alternates directions in the circuit. In contrast a circuit with constant current is referred to as a *direct current* circuit, or DC circuit.

§ 6.6 AC Power and RMS Voltage

The electrical power supplied by the power company is sinusoidal. The electric potential between the two sockets of an electrical outlet is oscillating.

$$V(t) = V_0 \cos \omega t$$

The voltage supplied in the U.S. is said to be 120 volts. If you examine the underside of an electrical appliance there will be printed something like

60Hz - 120V - 7.0AMPS

someplace near the UL listing mark. As you may have guessed the first mark indicate that the appliance is designed to operate on AC power that has a frequency of 60Hz. You might expect that the amplitude of the supplied electric potential, V_0 , would be 120V, and the amplitude of the current drawn by the appliance, I_0 , would be 7.0AMPS. This is not quite correct. These numbers are not the amplitudes but the amplitudes divided by $\sqrt{2}$, so that the actual amplitudes are greater by a factor of $\sqrt{2}$ than these values marked on the appliance. Thus $V_0 = (120\text{V})\sqrt{2} = 170\text{V}$ and $I_0 = (7.0\text{A})\sqrt{2}=9.9\text{A}$. In order to understand why this is so we need to consider the power dissipated in the appliance.

Recall that power is the product of the voltage and the current. Suppose for simplicity that the appliance that we are using is a toaster. This is simple because, as an electrical circuit, a toaster is simply a resistor. So our entire system, including the AC source, is diagramed as follows.

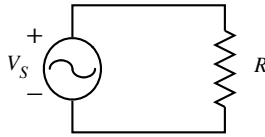

Because the current oscillates in time, the power dissipated in the resistor also oscillates in time.

$$\begin{aligned}
 P(t) &= I(t)V(t) \\
 &= I(t)I(t)R \\
 &= [I(t)]^2 R \\
 &= [I_0 \cos \omega t]^2 R \\
 &= I_0^2 R \cos^2 \omega t
 \end{aligned}$$

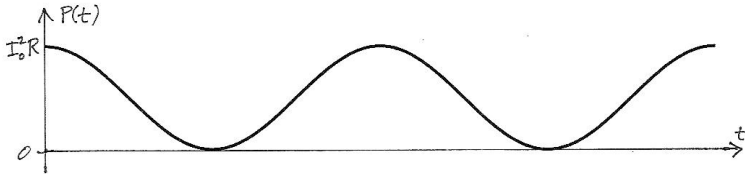

Notice that the power oscillates between zero and $I_0^2 R$ so that the average power supplied to the toaster is $\frac{1}{2}I_0^2 R$.

$$P_{\text{avg}} = \frac{I_0^2 R}{2} = \frac{I_0}{\sqrt{2}} \frac{I_0 R}{\sqrt{2}} = \frac{I_0}{\sqrt{2}} \frac{V_0}{\sqrt{2}} = (7.0\text{A})(120\text{V})$$

Notice that for a sinusoidal signal the root mean square (RMS) value is the amplitude divided by $\sqrt{2}$. Thus we can learn two things from this example. First, the values that are printed on the toaster are the RMS values. Second, the product of the RMS current and RMS voltage gives the average power. So in this example the average power consumed by the appliance is $P = (7.0\text{A})(120\text{V}) = 840\text{W}$.

▷ PROBLEM 6.4

A 60 watt light bulb has an average power output of 60 watts.

- What is the peak power?
- What is the resistance of the bulb?
- Is this resistance the same as the resistance that is required to dissipate 60 watts when connected to a 120 volt DC source?

§ 6.7 AC Circuit Elements

In many ways an AC circuit can be analyzed using the same techniques we used for DC circuits. In fact inductors and capacitors become as simple as resistors. **In an AC circuit, inductors and capacitors follow an adapted Ohm's Law:** the amplitude of the voltage on the

element is proportional to the amplitude of the current through the element, $V = ZI$, just like a resistor. The proportionality constant Z is called the impedance.

Let us see how this works for an inductor.

Suppose that the current through an inductor is $I(t) = I_0 \cos \omega t$. Then we know that the EMF (V_L) on the inductor is

$$V_L = L \frac{dI}{dt} = -\omega L I_0 \sin \omega t$$

So that the amplitude of the voltage oscillation is $\omega L I_0$.

$$V_{L_0} = \omega L I_0 = Z_L I_0 \quad \text{with} \quad Z_L \equiv \omega L$$

So we see that the amplitudes of the voltage and current are proportional. The constant $Z_L = \omega L$ is the equivalent of the resistance for an inductor.

Theorem: Impedance: Inductor

In an AC circuit the amplitude of the voltage on an inductor is proportional to the amplitude of the current flowing through the inductor.

$$V_{L_0} = Z_L I_0 \quad \text{with} \quad Z_L \equiv \omega L$$

The impedance of an inductor is $Z_L = \omega L$.

The actual voltage and current are not proportional, since one is a sine function and the other is the cosine function.

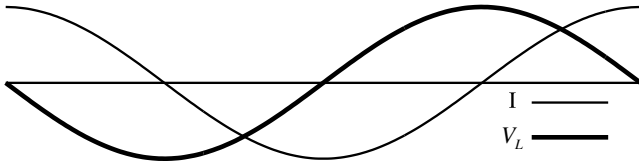

The voltage on an inductor reaches the peak value one quarter of a cycle before the current does. For this reason the voltage on an inductor in an AC circuit is said to lead the current by a phase of 90° .

A capacitor is similar.

$$V_C = \frac{1}{C} Q = \frac{1}{C} \int I dt = \frac{1}{\omega C} I_0 \sin \omega t$$

So that the amplitude of the voltage oscillation is $\frac{1}{\omega C} I_0$.

$$V_{C_0} = \frac{1}{\omega C} I_0 = Z_C I_0 \quad \text{with} \quad Z_C \equiv \frac{1}{\omega C}$$

So we see that the amplitudes of the voltage and current are proportional. The constant $Z_C = \frac{1}{\omega C}$ is the equivalent of the resistance for an capacitor.

Theorem: Impedance: Capacitor

In an AC circuit the amplitude of the voltage on a capacitor is proportional to the amplitude of the current flowing through the capacitor.

$$V_{C_0} = Z_C I_0 \quad \text{with} \quad Z_C \equiv \frac{1}{\omega C}$$

The impedance of an capacitor is $Z_C = \frac{1}{\omega C}$.

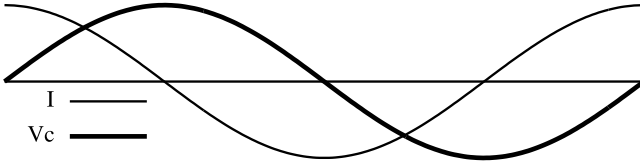

The voltage on a capacitor reaches the peak value one quarter of a cycle after the current does. For this reason the voltage on a capacitor in an AC circuit is said to follow the current by a phase of 90° .

§ 6.8 Phasor Diagrams

This relationship between the leading and following phases is often represented in a *phasor* diagram. As you may recall an oscillation can be thought of as the horizontal component of a circular motion. So we can represent the current or voltage in an AC circuit as the horizontal component of a circular motion.

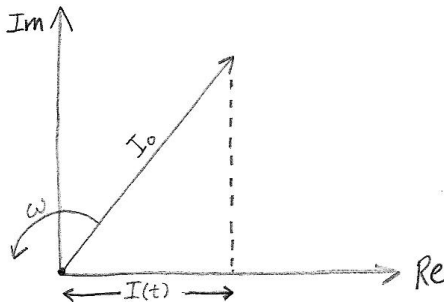

The current is represented as a vector with constant length I_0 that is rotating in the counter clockwise direction. The real physical current is the projection of this vector onto the horizontal (Re) axis.

One thing that is very nice about the phasor representation is that it allows us to clearly represent in a diagram the phase relationship between different quantities. Let us take the leading phase of the inductor

voltage as an example. The fact that the inductor voltage is one quarter of a cycle ahead of the current, means that the inductor voltage phasor is 90° ahead of the current phasor.

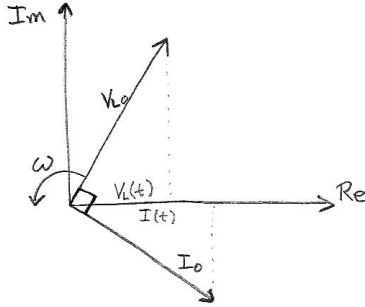

If you imagine the phasors rotating you can see that the projection of the voltage, onto the horizontal axis, will reach a peak one quarter of a cycle before the projection of the current reaches its peak.

Here is the phasor diagram for a capacitor.

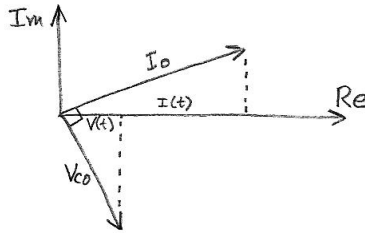

At this point the phasor diagram has only allowed us to represent what we already know. The phasor diagram is far more useful. For example the phasor diagram will allow us to use Kirchhoff's loop rule for AC circuits, as we will see in the following example. The idea of a phasor is useful in many areas of physics and engineering. We will see more examples in the next chapter.

EXAMPLE

Suppose that we have a capacitor and a resistor in series. What is the effective impedance of the combination. First imagine that we connect the combination to an AC source.

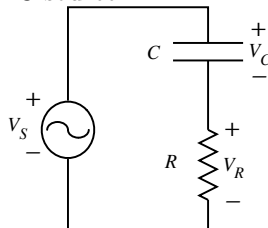

What we want to find is the ratio of the amplitude of the supply voltage and the amplitude of the current: V_{S_0}/I_0 .

Kirchhoff's loop rule gives us that

$$V_S(t) - V_C(t) - V_R(t) = 0 \longrightarrow V_S(t) = V_C(t) + V_R(t)$$

In the phasor diagram this implies that the sum of the phasors for V_C and V_R must be equal to the phasor of the source voltage V_S . Since the resistor phasor is parallel to the current phasor we know that the phasors for V_C must follow the phasor for V_R by 90° . Thus the sum (also V_S) forms the hypotenuse of a right triangle.



We can find the phasor for the sum of the voltage on the resistor and capacitor by adding the individual phasors like we add vectors. Also notice from the circuit diagram that the sum of the voltages on the resistor and capacitor is equal to the voltage on the supply: $V_S = V_R + V_C$.

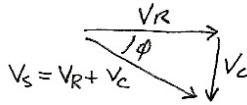

Since the lengths of the phasors are the amplitudes of the voltages we can use the pythagorean theorem to find that

$$\begin{aligned} V_{S_0}^2 &= V_{R_0}^2 + V_{C_0}^2 = (RI_0)^2 + (Z_C I_0)^2 \\ &\longrightarrow \frac{V_{S_0}^2}{I_0^2} = R^2 + Z_C^2 \\ &\longrightarrow Z_{\text{eff}} = \frac{V_{S_0}}{I_0} = \sqrt{R^2 + Z_C^2} = \sqrt{R^2 + \frac{1}{(\omega C)^2}} \end{aligned}$$

We see that the impedances do not simply add when the components are in series. In this case the square of the impedance was the sum of the squares of parts. This is **not** a general rule. We can also find the phase angle (ϕ) between the supply voltage and the current.

$$\tan \phi = \frac{-V_{C_0}}{V_{R_0}} = \frac{-Z_C I_0}{R I_0} = \frac{-Z_C}{R} = \frac{-1}{\omega R C}$$

There is a very significant difference between the resistance of a resistor and the impedance of a capacitor or inductor: the impedance depends on the frequency. In the previous example we see that the

effective impedance of the system depends on ω . This can be a useful property, since sometimes we wish to treat different frequencies differently. For example in an audio system, there are big speakers for low frequencies and small speakers for high frequencies, but the signal coming from the amplifier to the speakers contains both high and low frequencies. Let us see how we can use a capacitor and resistor in series to split the signal so that the appropriate signal goes to each speaker.

EXAMPLE For the circuit in the previous example, let us find the voltage on the capacitor and resistor relative to the voltage from the source.

$$G_R(\omega) \equiv \frac{V_{R_0}}{V_{S_0}} = \frac{V_{R_0}/I_0}{V_{S_0}/I_0} = \frac{R}{\sqrt{R^2 + 1/(\omega C)^2}} = \frac{1}{\sqrt{1 + 1/(\omega RC)^2}}$$

$$G_C(\omega) \equiv \frac{V_{C_0}}{V_{S_0}} = \frac{V_{C_0}/I_0}{V_{S_0}/I_0} = \frac{1/\omega C}{\sqrt{R^2 + 1/(\omega C)^2}} = \frac{1}{\sqrt{(\omega RC)^2 + 1}}$$

These ratios are called the *gain*.

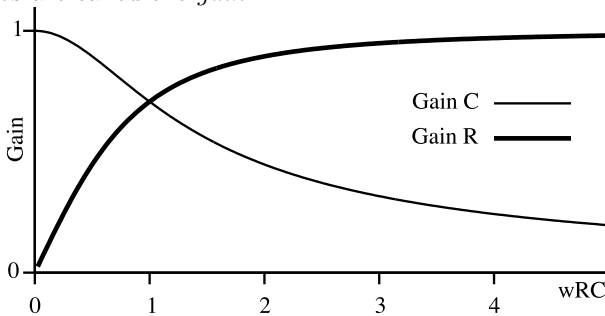

So we see that the voltage on the capacitor is equal to the source voltage at low frequencies and drops to zero at high frequencies, while the voltage on the resistor does just the reverse. So we see that the signal from the source is sorted by this circuit, high frequencies to the capacitor and low frequencies to the resistor. Thus we can send the voltage from the capacitor to the large speakers and the voltage from the resistor to the small speakers.

▷ **PROBLEM 6.5**

Suppose that you build a RL circuit instead of the RC, that is you replace the capacitor with an inductor in the previous example.

- Find the gain for the resistor and inductor.
- Graph the gain for the resistor and inductor.
- Which will pass low frequencies better than high frequencies.

▷ PROBLEM 6.6

Show that this LRC circuit has a maximum current when $\omega = \sqrt{\frac{1}{LC}}$. This is called the *resonance* frequency.

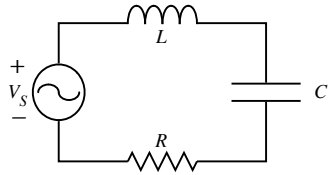

§ 6.9 Homework

▷ PROBLEM 6.7

Consider the hemispherical closed surface of radius R as shown. If the hemisphere is in a uniform magnetic field that makes an angle θ with the vertical, calculate the magnetic flux through the flat surface S_1 . Calculate the flux through the hemispherical surface S_2 .

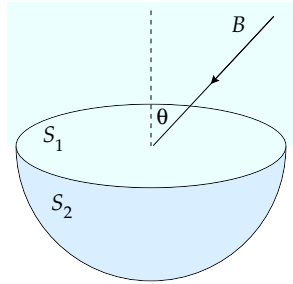

▷ PROBLEM 6.8

A powerful electromagnet has a field of 1.6T and a cross-sectional area of 0.20m^2 . If we place a coil having 200 turns and a total resistance of 20Ω around the electromagnet and then turn off the power to the electromagnet in 20ms, what is the current induced in the coil?

▷ PROBLEM 6.9

A rectangular loop of area A is placed in a region where the magnetic field is perpendicular to the plane of the loop. The magnitude of the field is allowed to vary in time according to $B = B_0 e^{-t/\tau}$. What is the induced emf as a function of time?

▷ PROBLEM 6.10

A long, straight wire carries a current $I = I_0 \sin(\omega t + \delta)$ and lies in the plane of a rectangular loop of N turns as shown. Determine the emf induced in the loop by the magnetic field of the wire.

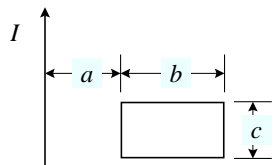

▷ PROBLEM 6.11

A magnetic field directed into the page changes with time according to $B = at^2 + b$. The field has a circular cross-section of radius R . What are the magnitude and direction of the electric field at a distance r from the center of the field.

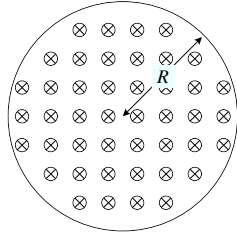

▷ PROBLEM 6.12

For the situation in the previous problem if $B = (2.0t^3 - 4.0t^2 + 0.80)\text{T}$ and $R = 2.5\text{cm}$. Calculate the magnitude and direction of the force exerted on an electron located at a distance $r = 2R$ from the center of the field at the time $t = 2.0\text{s}$.

▷ PROBLEM 6.13

A circular coil enclosing an area of 100cm^2 is made of 200 turns of copper wire. Initially a 1.10T uniform magnetic field points perpendicularly upward through the plane of the coil. The direction of the field then reverses. During the time the field is changing its direction, how much charge flows through the coil if the resistance of the coil is $R = 5.0\Omega$.

▷ PROBLEM 6.14

The rotating loop in an ac generator is a square 10cm on a side. It is rotated at 60 Hz in a uniform field of 0.80T . Calculate (a) the flux through the loop as a function of time, (b) the emf induced in the loop, (c) the current induced in the loop for a loop resistance of 1.0Ω , (d) the power dissipated in the loop, and (e) the torque that must be exerted to rotate the loop.

▷ PROBLEM 6.15

A solenoid has n turns per unit length, radius a and carries a current I .

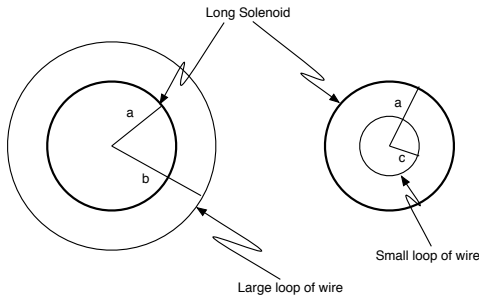

(a) A large circular loop of radius $b > a$ and N turns encircles the solenoid at a point far away from the ends of the solenoid. Find the magnetic flux through the loop.

(b) A small circular loop of N turns and radius $c < b$ is completely inside the solenoid, far from its ends, with its axis parallel to that of the solenoid. Find the magnetic flux through this small loop.

▷ PROBLEM 6.16

The two circular loops shown below have their planes parallel to each other.

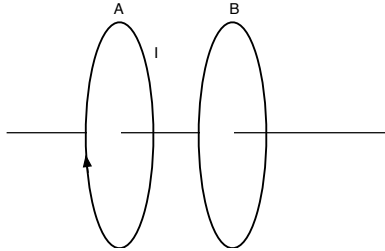

As viewed from A toward B, there is a counter-clockwise current in loop A. Give the direction of the induced current in loop B and determine whether the loops attract or repel each other if the current in loop A is (a) increasing and (b) decreasing.

▷ PROBLEM 6.17

A bar magnet moves with constant velocity along the axis of a loop as shown in the figure below.

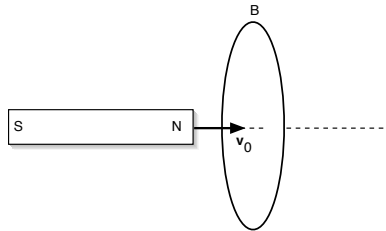

(a) Make a qualitative graph of the flux ϕ_B through the loop as a function of time. Indicate the time t_1 when the magnet is halfway through the loop.

(b) Sketch a graph of the current I in the loop versus time, choosing I to be positive when it is counterclockwise as viewed from the left.

▷ PROBLEM 6.18

Given the circuit below, assume that the switch S has been closed for a long time so that steady state currents exist in the circuit.

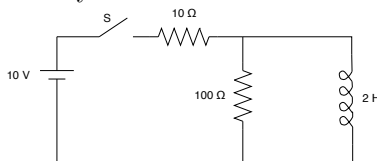

Ignore any resistance of the inductor L . (a) Find the battery current, the current in the $100\ \Omega$ resistor, and the current through the inductor. (b) Find the initial voltage across the inductor when switch S is opened. (c) Give the current as a function of time measured from the instant of opening the switch S .

▷ PROBLEM 6.19

A 2.00H inductor carries a steady current of 0.500A . When the switch in the circuit is thrown open, the current disappears in 10ms . What is the average induced emf in the inductor during this time?

▷ PROBLEM 6.20

A coiled telephone cord has 70 turns, a cross sectional diameter of 1.3 cm , and an unstretched length of 60 cm . Determine an approximate value for the self inductance of the unstretched cord.

▷ PROBLEM 6.21

A 10.0mH inductor carries a current $I = I_{\max} \sin \omega t$, with $I_{\max} = 5.00\text{A}$ and $\omega/2\pi = 60.0\text{Hz}$. What is the back emf as a function of time?

▷ PROBLEM 6.22

The switch in the circuit below is closed at time $t = 0$. Find the current in the inductor and the current through the switch as functions of time if $V = 10.0\text{V}$, $R = 4.00\ \Omega$ and $L = 1.00\text{H}$.

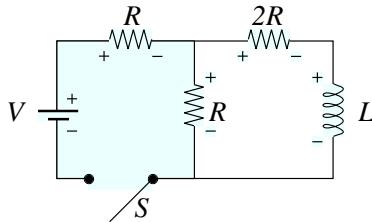

▷ PROBLEM 6.23

Show that $I = I_0 e^{-t/\tau}$ is a solution of the differential equation

$$IR + L \frac{dI}{dt} = 0$$

where $\tau = L/R$ and I_0 is the current at $t = 0$.

▷ PROBLEM 6.24

An air-coil solenoid with 68 turns is 8.0 cm long and has a diameter of 1.2 cm . How much energy is stored in its magnetic field when it carries a current of 0.77A .

▷ PROBLEM 6.25

The switch in the circuit below is connected to point a for a long time. After the switch is thrown to point b find (a) the frequency of oscillation in the LC circuit, (b) the maximum charge on the capacitor, (c) the

maximum current in the inductor, and (d) the total energy stored in the circuit at time t .

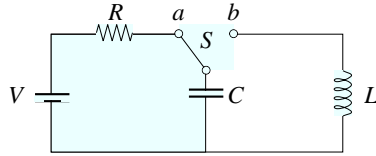

▷ PROBLEM 6.26

Show that the rms voltage of the pictured “sawtooth” wave is $V_0/\sqrt{3}$.

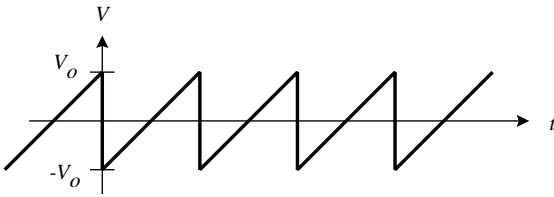

▷ PROBLEM 6.27

What is the resistance of a light bulb that uses an average power of 75W when connected to a 60Hz power source having a maximum voltage of 170 V? What is the resistance of a 100W bulb?

▷ PROBLEM 6.28

An inductor has an AC current of frequency 50Hz passing through it. The maximum voltage is 100V and the maximum current is 7.5A. What is the inductance of the inductor? The frequency is now changed to ω_{new} while the voltage is held constant. The maximum current is now 2.5A. What is the angular frequency ω_{new} ?

▷ PROBLEM 6.29

A 1.0mF capacitor is connected to a standard wall outlet. Determine the current in the capacitor at $t = (1/180)\text{s}$, assuming that at $t = 0$ the energy stored on the capacitor is zero.

▷ PROBLEM 6.30

For what linear frequencies does a $22.0\mu\text{F}$ capacitor have a impedance below 175Ω ? Over this same frequency range, what is the impedance of a $44.0\mu\text{F}$?

▷ PROBLEM 6.31

A sinusoidal voltage $v(t) = V_{\text{max}} \cos \omega t$ is applied to a capacitor. Write an expression for the instantaneous charge on the capacitor. What is the instantaneous current in the circuit?

▷ PROBLEM 6.32

At what frequency does the inductive impedance of a $57\mu\text{H}$ inductor equal the capacitive impedance of a $57\mu\text{F}$ capacitor.

▷ PROBLEM 6.33

A series AC circuit contains the following components: $R = 150\Omega$, $L = 250\text{mH}$, $C = 2.00\mu\text{F}$, and a generator with $V_{\text{max}} = 120\text{V}$ operating at 50.0Hz . Calculate the (a) inductive impedance, (b) capacitive impedance, (c) impedance, (d) maximum current, and (e) phase angle. ■

▷ PROBLEM 6.34

An RLC circuit consists of a 150Ω resistor, a $21\mu\text{F}$ capacitor, and a 460mH inductor, connected in series with a 120V , 60Hz function generator. What is the phase angle between the current and the applied voltage? Which reaches its maximum earlier, the current or the voltage?

▷ PROBLEM 6.35

Calculate the resonance frequency of a series RLC circuit for which $C = 8.40\mu\text{F}$ and $L = 120\text{mH}$.

▷ PROBLEM 6.36

An RLC circuit is used in a radio to tune into an FM station broadcasting at 99.7MHz . The resistance in the circuit is 12.0Ω , and the inductance is $1.40\mu\text{H}$. What capacitance should be used?

§ 6.10 Summary

Definitions**Facts****Theorems**

Ampere's Law:

$$\oint \vec{B} \cdot d\vec{\ell} = \mu_0 \int \vec{J} \cdot d\vec{A} + \mu_0 \epsilon_0 \frac{d}{dt} \int \vec{E} \cdot d\vec{A}$$

Faraday's Law:

$$\oint \vec{E} \cdot d\vec{\ell} = -\frac{d}{dt} \int \vec{B} \cdot d\vec{A}$$

AC Circuits

Capacitor: The phase of the voltage across a capacitor is 90° behind the phase of the current through the capacitor. The amplitude of the voltage and current are related as follows.

$$V_{C0} = \frac{1}{\omega C} I_{C0}$$

Inductor: The phase of the voltage across an inductor is 90° ahead of the phase of the current through the inductor. The amplitude of the voltage and current are related as follows.

$$V_{L0} = \omega L I_{L0}$$

7

Wave Optics

§ 7.1 Maxwell Equations

Let us write down, in one place, all of the fundamental equations about the electric and magnetic fields.

$$\text{Gauss's Law} \quad \oint \vec{E} \cdot d\vec{A} = \frac{1}{\epsilon_0} \int \rho \, dV$$

$$\text{Faraday's Law} \quad \oint \vec{E} \cdot d\vec{\ell} = -\frac{d}{dt} \int \vec{B} \cdot d\vec{A}$$

$$\text{Ampere's Law} \quad \oint \vec{B} \cdot d\vec{\ell} = \mu_0 \int \vec{J} \cdot d\vec{A} + \mu_0 \epsilon_0 \frac{d}{dt} \int \vec{E} \cdot d\vec{A}$$

$$\text{Gauss's Law for } B \quad \oint \vec{B} \cdot d\vec{A} = 0$$

These equations as a group are known as the Maxwell Equations.

The last equation, which we have not discussed before, can be understood to say that there is no magnetic equivalent to the electric charge. That is, that there are no magnetic charges, places where magnetic field lines begin or end, thus that magnetic field lines do not end. If you want to think of the magnetic field as a flowing fluid, with B the velocity of the fluid, then this law says that the fluid does not compress: B flows like water, when it spreads out the velocity decreases, when it goes through a narrow region it speeds up, the volume rate of flow is a constant.

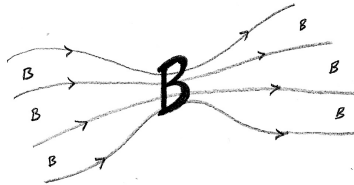

Ok, so the new law tells us that there are no magnetic charge, let us see what the Maxwell equations look like in a region where there is no **electric** charge ($\rho = 0$) and no current ($J = 0$).

$$\begin{array}{ll}
 \text{Gauss's Law} & \oint \vec{E} \cdot d\vec{A} = 0 \\
 \text{Faraday's Law} & \oint \vec{E} \cdot d\vec{\ell} = -\frac{d}{dt} \int \vec{B} \cdot d\vec{A} \\
 \text{Ampere's Law} & \oint \vec{B} \cdot d\vec{\ell} = \mu_0 \epsilon_0 \frac{d}{dt} \int \vec{E} \cdot d\vec{A} \\
 \text{a new Law} & \oint \vec{B} \cdot d\vec{A} = 0
 \end{array}$$

You can see that the equations are essentially the same in E and B . Investigating these equations led Maxwell to discover that in regions where there is no current or charge that there can be traveling waves as pictured below.

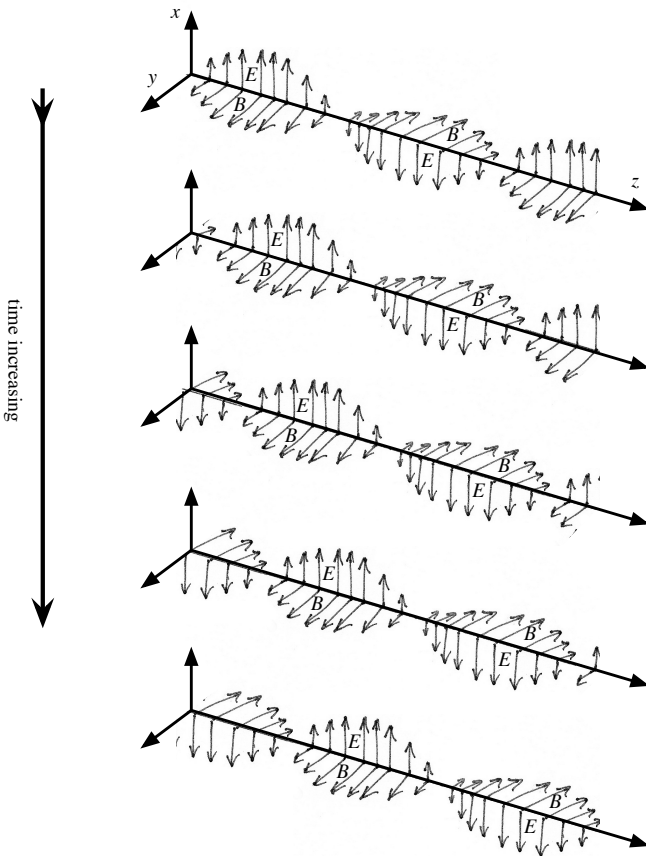

What is drawn is the magnetic field and electric field at various posi-

tions along the z -axis. Notice that the magnitude of the field oscillates, as one moves along the z -axis. This pattern of spacial oscillations of the field, travels to the right along the axis as time passes. Also notice that E and B are perpendicular, and that the direction of travel is perpendicular to both E and B .

Maxwell also found that the equations predict the velocity at which these *electromagnetic* waves travel.

$$v_{\text{EM}} = \sqrt{\frac{1}{\mu_0 \epsilon_0}}$$

From the known values of μ_0 and ϵ_0 , Maxwell computed that the velocity of these EM waves is the **same** as the velocity of light. He concluded, rightly, that light and electromagnetic waves are the same thing. This was a huge leap in our understanding of light.

Fact: Electromagnetic Waves and Light

Light is an electromagnetic wave.

▷ PROBLEM 7.1

Show that $1/\sqrt{\mu_0 \epsilon_0} = c$.

§ 7.2 Describing Oscillations

We need some terminology to make it easier to talk about sinusoidal waves and oscillations. The central idea of a wave is encapsulated in the term *phase* of an oscillation. The word phase is used here in the same way as the word is used to describe the cycle of the moon: new moon, waxing crescent, first quarter, full moon, etc.



In a system with a periodic cycle, the phase of the system describes what point in the cycle the system is currently occupying.

Recall from the section on AC circuits that we can describe a sinusoidal oscillation as the horizontal component of a rotation. Thus the phase of a sinusoidal oscillation can be described by giving the angle of rotation, ϕ . When the phase is $\phi = 0$, the oscillation is at its greatest positive extension. When the phase is $\phi = \pi/2$ the oscillation is at zero and with a negative velocity. When the phase is $\phi = \pi$ the oscillation is at its greatest negative extension. When the phase is $\phi = 3\pi/2$ the oscillation is zero but with a positive velocity. These and other phases of an oscillation are depicted in the figure below.

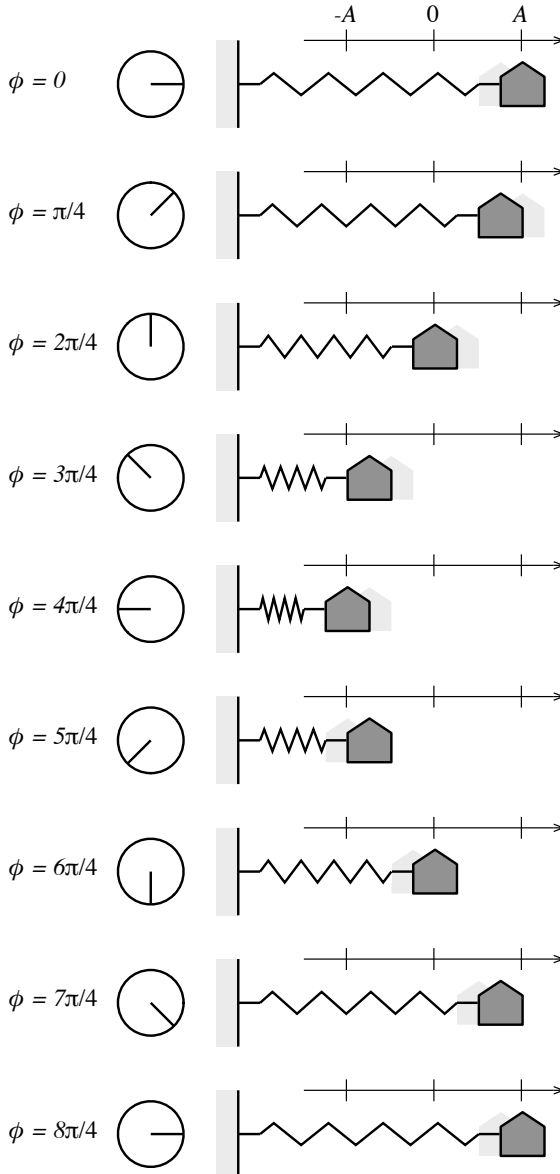

The actual value of the displacement (x) is the amplitude of the oscillation times the cosine of the phase angle.

$$\text{Displacement} = \text{Amplitude} \times \cos \phi$$

$$x = A \cos \phi$$

For a harmonic oscillator the phase increases at a constant rate:

$$\frac{d\phi}{dt} = \omega \longrightarrow \phi = \omega t + \phi_0$$

and so the displacement is

$$x = A \cos(\omega t + \phi_0)$$

▷ PROBLEM 7.2

An oscillator has an amplitude of 3.2. At this instant the displacement of the oscillator is 1.4. What are the two possible phases of the oscillator at this instant?

▷ PROBLEM 7.3

You have a mass connected to a spring.

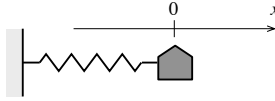

You start the mass oscillating in the following ways. What is the initial phase ϕ_0 in each case.

- Stretch the spring to the right, at $t = 0$ release the mass.
- Compress the spring to the left, at $t = 0$ release the mass.
- At $t = 0$ strike the mass so that it begins moving to the left.
- At $t = 0$ strike the mass so that it begins moving to the right.
- At $t = 0$ the mass is at the position $x_0 = 2.0\text{m}$ and has a velocity of $v_0 = 3.0\frac{\text{m}}{\text{s}}$ (assume that $\omega = 5.0\frac{\text{rad}}{\text{s}}$).

▷ PROBLEM 7.4

It takes a time of $T = 0.025\text{s}$ in order for an oscillator to complete one cycle. What is the angular frequency (ω) of the oscillator?

§ 7.3 Describing Waves

Consider dropping a rock into a pool of still water. Ripples spread out from the point at which the rock enters the water. If you examine the motion of the water at one fixed point, the surface of the water moves up and down as successive waves move past. The height of the water at our fixed point is an oscillation. This is true at other points a well, at each location the height of the water oscillates. Since an oscillation is so simple, the only thing that can differ between one point and another is the amplitude of the oscillation and the initial phase ϕ_0 . Let us write the height of the water, at position \vec{r} and time t , as $y(\vec{r}, t)$. Since the oscillation at each point is a harmonic oscillation we can write:

$$y(r, t) = A(\vec{r}) \cos[\omega t + \phi_0(\vec{r})]$$

Where the amplitude $A(\vec{r})$ and initial phase $\phi_0(\vec{r})$ both depend on the position \vec{r} .

In the situation where the wave spreads out from a point source (such as a rock dropped in the water), the wave travels outward at a speed v . Because of this, the oscillation at a distance r from the source will be the same as the oscillation of the source, only delayed by the time ($t_d = r/v$) it takes for the wave to travel the distance r from the source to the observation point. Thus the phase of the oscillation at a position r at a time $t + t_d$, will be the same as the phase of the oscillation at the source ($r = 0$) at time t .

$$\begin{aligned}\phi(r, t + t_d) &= \phi(0, t) \\ \omega(t + t_d) + \phi_0(r) &= \omega t + \phi_0(0) \\ \phi_0(r) &= \phi_0(0) - \omega t_d \\ \phi_0(r) &= \phi_0(0) - \omega \frac{r}{v} \\ \phi_0(r) &= \phi_0(0) - kr \quad \text{with} \quad k \equiv \frac{\omega}{v}\end{aligned}$$

For convenience we usually pick our zero of time so that $\phi_0(0) = 0$, so that $\phi_0(r) = -kr$ and $y(r, t) = A(r) \cos(\omega t - kr)$.

Theorem: Wave due to a Sinusoidal Point Source

A general wave radiating from a point source can be written down mathematically as follows:

$$\begin{aligned}\psi(r, t) &= A(r) \cos(\omega t - kr) \\ &= A(r) \cos\left(\frac{2\pi}{T}t - \frac{2\pi}{\lambda}x\right)\end{aligned}$$

where $k = \omega/v$ and $T \equiv \frac{2\pi}{\omega}$ and $\lambda \equiv \frac{2\pi}{k}$ are the period and wavelength as described below.

Definition: Wavelength

If you freeze a sinusoidal wave at one point in time, the distance you must travel along the wave in order to go through a complete cycle of the oscillation, is called the *wavelength*. We use the symbol λ to represent the wavelength in equations.

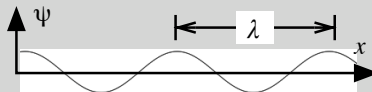

Definition: Period and Frequency

If you stand in one place and allow the wave to pass you, the time you must wait in order to be back at the same point in the oscillation as when you started is called the *period*. We use the symbol T to represent the period in equations.

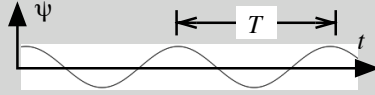

The *frequency* is the inverse of the period.

$$f = \frac{1}{T}$$

Note that the angular frequency is $\omega = 2\pi f$. Both frequencies are really the same thing, they both measure the rate of the oscillation, it is just that one is in the units of radians and the other is in the units of cycles. So you can convert between units by using the fact that one cycle is 2π radians: $\omega = \frac{\text{radians}}{\text{seconds}} = \frac{\text{radians}}{\text{cycle}} \frac{\text{cycles}}{\text{seconds}} = 2\pi f$.

Notice that the relationship between the angular frequency and the wave number can be rewritten in terms of the wavelength and period.

$$k = \frac{\omega}{v} \longrightarrow 2\pi/\lambda = \frac{2\pi/T}{v} \longrightarrow \lambda = vT$$

So we can also think of the wavelength as the distance the wave travels in one period, or writing the equation as $T = \lambda/v$, we can think of the period as the time it takes to travel one wavelength.

Let us summarize the relationships between the different parameters that describe a wave.

Time scale:

$$\omega = \frac{2\pi}{T} = 2\pi f$$

Length scale:

$$k = \frac{2\pi}{\lambda}$$

Relationship between time and length scales:

$$k = \frac{\omega}{v} \quad \text{OR} \quad \lambda = vT \quad \text{OR} \quad \lambda f = v$$

▷ PROBLEM 7.5

For the following wave, graphed at seven different times, determine the amplitude, wavelength, period, frequency, angular frequency, wave number, and velocity. Write the function $y(x,t)$ that describes the wave.

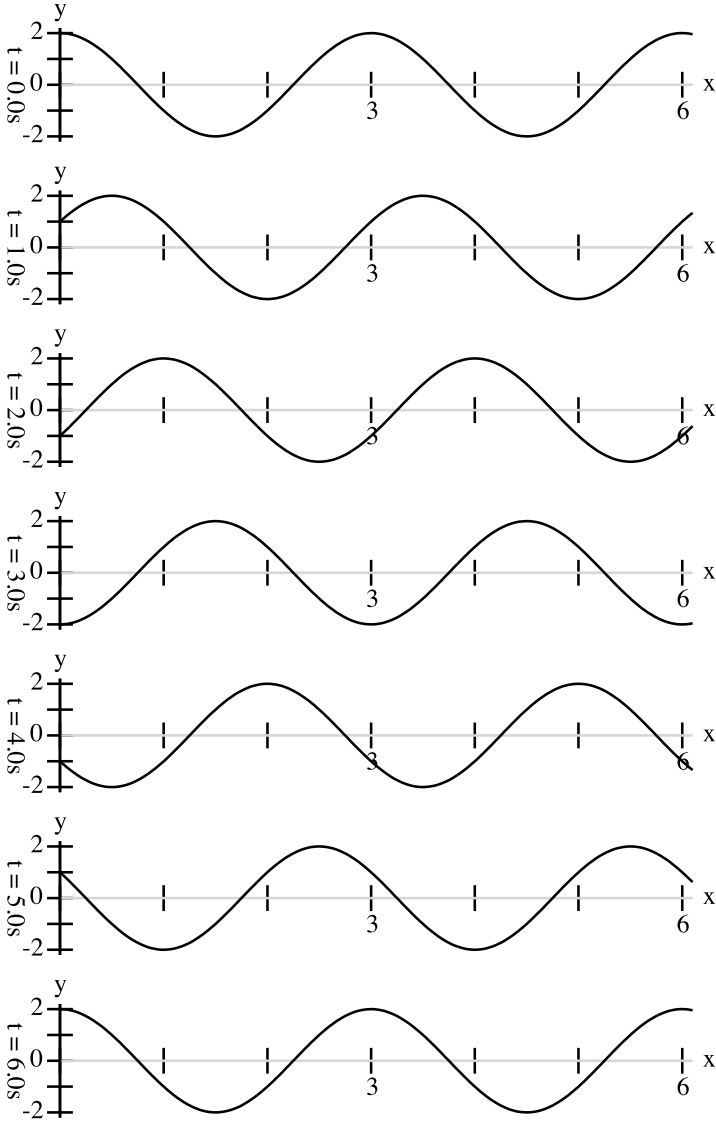

§ 7.4 Electromagnetic Waves

With our eyes we are able to see electromagnetic (EM) waves that have wavelengths between about 400nm to 700nm. We experience light with different wavelengths as different colors, as indicated in the following table.

Wavelength	Frequency	Perceived Color
740 to 625 nm	405 to 480 THz	red
625 to 590 nm	480 to 510 THz	orange
590 to 565 nm	510 to 530 THz	yellow
565 to 520 nm	530 to 580 THz	green
520 to 500 nm	580 to 600 THz	cyan
500 to 430 nm	600 to 700 THz	blue
430 to 380 nm	700 to 790 THz	violet

Note that the frequency and wavelength of an EM wave are related by $\lambda f = c$ where c is the speed of light.

But this is only a small range of EM spectrum.

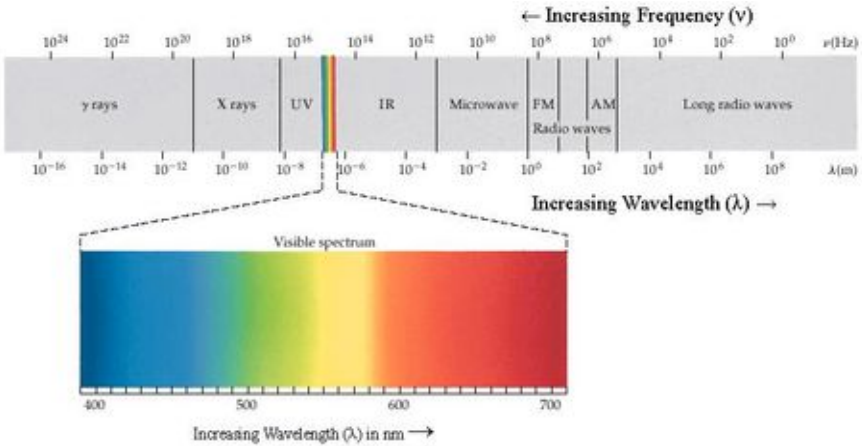

We see that there are a number of familiar items in the spectrum: x-rays, microwaves, and radio waves are all EM waves. The range of the spectrum just above and just below the visible range are called the *ultraviolet* (UV) and *infrared* (IR). The prefixes ultra (above) and infra (below) refer to the frequency not the wavelength.

▷ PROBLEM 7.6

Your microwave oven is filled with EM waves with a frequency of about 3 GHz. What is the wavelength of the wave? The microwave oven heats up the objects in the oven, because the oscillating EM wave causes an oscillating electric force on the electric dipoles in the object, which causes the dipoles to oscillate. The frequency of a standard microwave

oven is tuned to a natural oscillation frequency of the water molecule. Note that a cellular phone uses about the same frequency as an oven, a cellular phone is a small microwave emitter, so you are slowly cooking your brain when you hold the phone to your head.

▷ PROBLEM 7.7

Compute the wavelength of an FM radio station that transmits at a frequency of 94.1 MHz.

§ 7.5 Interference of Waves

We have claimed that light is an EM wave because it has the same speed as an EM wave. We have not looked at the consequences of the fact that light is a wave. One of the principle characteristics of waves is their ability to interfere with each other when two or more of the waves are combined. The following example will demonstrate this interference.

Consider the follow situation. You have a point source of waves, and near this source you have a reflecting surface.

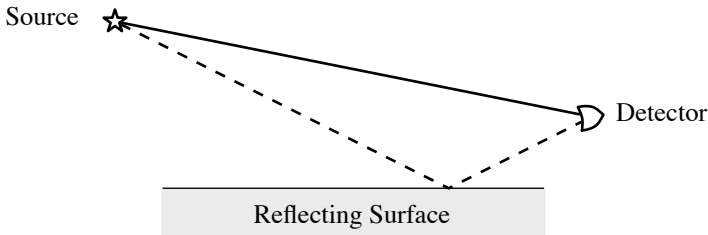

The wave arrives at the detector by two different paths, a direct path and a reflected path. The wave travels a distance r_1 along the direct path and a distance r_2 along the reflected path. If the reflected path was blocked the oscillation at the detector would be just that due to the direct path, $\psi_1(t) = A_1 \cos(\omega t + \phi_1)$ where $\phi_1 = -kr_1$. Similarly if the direct path is blocked the oscillation at the detector would be just that due to the reflected path, $\psi_2(t) = A_2 \cos(\omega t + \phi_2)$ where $\phi_2 = -kr_2$. When both paths are open then the resultant wave at the detector will be the sum of the waves from each path

$$\begin{aligned} \psi(t) &= \psi_1(t) + \psi_2(t) \\ &= A_1 \cos(\omega t + \phi_1) + A_2 \cos(\omega t + \phi_2) \end{aligned}$$

Using the phasor diagram for these two oscillations we can find the amplitude of their sum.

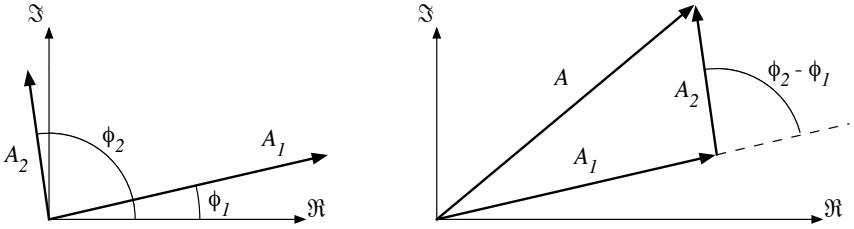

The law of cosines gives the amplitude, A , in terms of the amplitudes A_1 and A_2 .

$$A^2 = A_1^2 + A_2^2 + 2A_1A_2 \cos(\phi_2 - \phi_1)$$

Theorem: Addition of Two Waves

If two waves (with the same frequency) come together at a detector, the amplitude A of the resultant wave at the detector will be as follows.

$$A^2 = A_1^2 + A_2^2 + 2A_1A_2 \cos(\phi_2 - \phi_1)$$

In general the power carried by a wave is proportional to the square of the amplitude of the wave, so this result can be rewritten in terms of the power.

$$P = P_1 + P_2 + 2\sqrt{P_1}\sqrt{P_2} \cos(\phi_2 - \phi_1)$$

Below is graphed the power at a detector where two waves come together, The power of one wave is 25 mW and the power of the other waves is 4 mW.

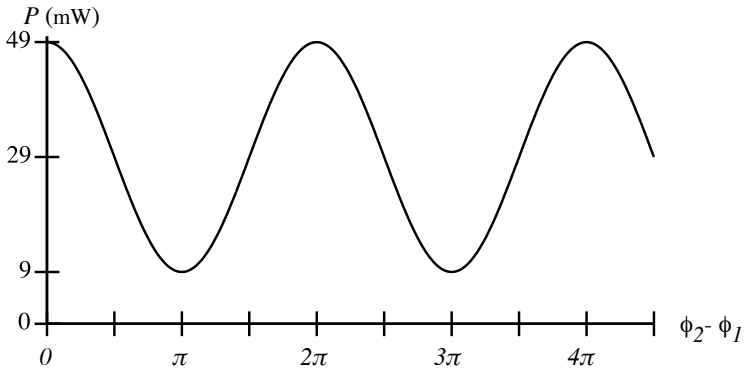

Notice the following points:

- The power at the detector can be less with both sources on than with just one of them on.
- The maximum power occurs when the phase difference is an even multiple of π . The waves are said to be perfectly *in-phase*.

- The minimum power occurs when the phase difference is an odd multiple of π . The waves are said to be directly *out-of-phase*.
- When the phase difference is an odd multiple of $\pi/2$, the power is equal to the sum of the powers of the individual signals.

▷ PROBLEM 7.8

Suppose that you are at home talking on your wireless phone, and you walk near your refrigerator. Since the refrigerator is made of metal it acts as a reflector for the microwave signal going to and from your phone. Because of this there are two paths between your phone and the transceiver (the base that phone sits in) that it is communicating with.

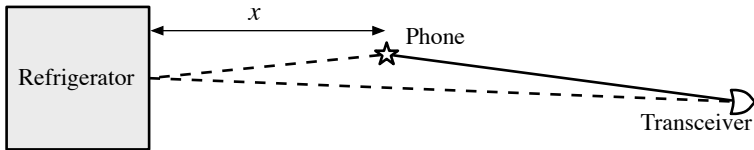

When you are a distance x from the refrigerator the signal that reflects from the refrigerator must travel a distance $2x$ further. Assuming that the reflected amplitude is one half of the direct amplitude, graph the power of the signal as a function of your distance from the refrigerator. Assume that the wavelength of the signal is 10cm. Are there places that it would be better to avoid?

§ 7.6 Interferometer

It is possible to build a device that measures very small motions by using interference.

The device represented in the diagram below is called an interferometer.

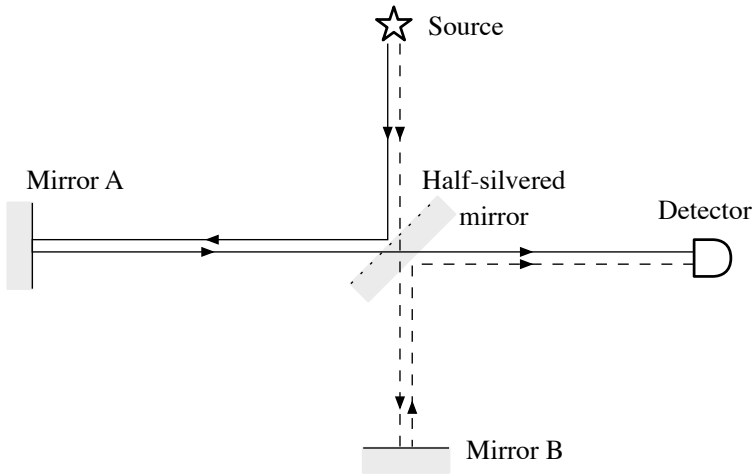

A beam of light strikes a half-silvered mirror. The half silvered mirror reflects half of the wave toward mirror A and transmits the other half toward mirror B. The part that strikes mirror A, is reflected back (to the right) toward the half-silvered mirror where it is again split, half passing through to the detector on the left and half being reflected back toward the source. The part of the beam that strikes mirror B is also split so that half reaches the detector.

So we see that there are two path by which light can reach the detector, one path that has been reflected from mirror A, and another path that has been reflected from mirror B. By adjusting the location of mirror A we can adjust the path length of the light. In this way the relative phase of path A and B can be adjusted. Suppose that we have adjusted the path length so that the power at the detector is a maximum. Then $\phi_A - \phi_B$ is an even multiple of π .

Now suppose that we move mirror A a distance of $\frac{\lambda}{4}$ to the left. This will increase the path length of by $\Delta r_A = 2\frac{\lambda}{4} = \frac{\lambda}{2}$ since the path includes the extra bit of length twice, once on the way to the mirror and once on the way back from the mirror. But a change in the path length of Δr_A will change the phase by $-k\Delta r_A = -\frac{2\pi}{\lambda}\frac{\lambda}{2} = -\pi$. Thus $\phi_A - \phi_B$ is now an odd multiple of π , and the power will be at a minimum. By observing the intensity of the light at the detector we can easily tell if it has gone from bright to dim (maximum to minimum). Thus we can easily detect when the mirror has been moved by $\lambda/4$. A common laser pointer has a wavelength of something like 650nm so one quarter of this is 162nm. So an interferometer can be used as a “ruler” with markings about 162nm apart. This is a very small distance, for comparison, the finest human hair is about 20,000 nm in diameter.

§ 7.7 Interference of Two Sources

Suppose that we have two wave sources that are in phase with each other.

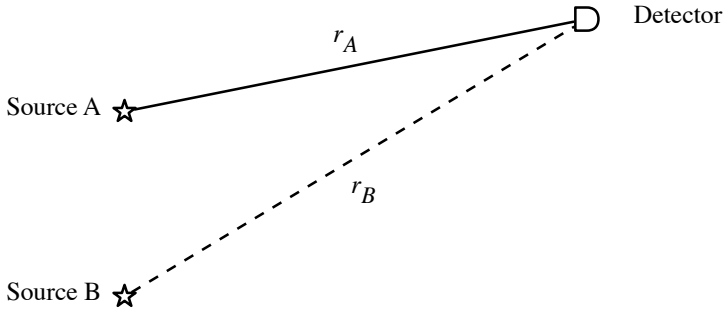

While the sources are in phase, the waves are not when they reach the detector because they must travel a different distance: at the detector the phase difference between the waves will be $\phi_A - \phi_B = k(r_B - r_A) = k \Delta r = 2\pi \frac{\Delta r}{\lambda}$. The minimum and maximum power occur when this phase difference is an odd and even multiple of π . That is when

$$2\pi \frac{\Delta r}{\lambda} = m\pi \quad \begin{cases} \text{max} & m \text{ is even.} \\ \text{min} & m \text{ is odd} \end{cases}$$

$$\Delta r = m \frac{\lambda}{2} \quad \begin{cases} \text{max} & m \text{ is even.} \\ \text{min} & m \text{ is odd} \end{cases}$$

Theorem: Interference of Two Sources

If you have two wave sources that are in phase with each other, the minimum and maximum of the power occur at points where the path difference is an odd (min) or even (max) multiple of half of the wavelength of the wave.

$$\Delta r = m \frac{\lambda}{2} \quad \begin{cases} \text{max} & m \text{ is even.} \\ \text{min} & m \text{ is odd} \end{cases}$$

▷ PROBLEM 7.9

Draw two points that are 3 cm apart on a piece of paper.

- Find all points on the paper that have $\Delta r = 0$.
- Find all points on the paper that have $\Delta r = 1\text{cm}$.
- Find all points on the paper that have $\Delta r = 2\text{cm}$.
- If $\lambda = 1.0\text{cm}$ what are the locations of the maximum and minimum of power?
- If $\lambda = 2.0\text{cm}$ what are the locations of the maximum and minimum of power?

§ 7.8 Far Field Approximation

In most cases the detector is placed far from the two sources, far in the sense that the distance from the sources to the detector r is much bigger than the distance between the sources, d . There is a useful approximation for the path difference that can be used when the detector is far from the source.

First consider the case when the detector is **not** far, as pictured in the figure to the right. Notice that if we make of a section of arc, with the center at the detector, and going through the closest source, and then consider the section of the path from the furthest source that is cut off by this arc. This cut off section (marked as Δr in the figure) is equal to the path difference. Also notice that the arc is perpendicular to the path.

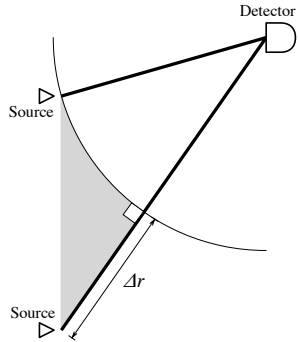

Now imagine moving the detector further from the sources, as pictured in the diagram below. The section of arc that is between the two paths, subtends a smaller and smaller angle, and thus this section of arc becomes closer and closer to a straight line. At the same time the grey region becomes a right triangle.

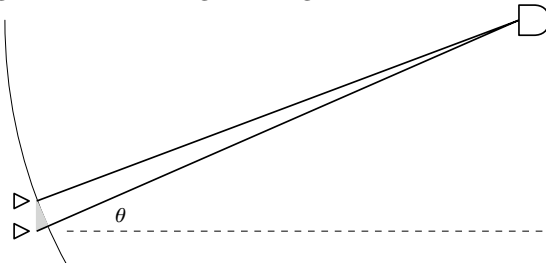

Let us examine this right triangle more closely. We see from the diagram to the right that

$$\sin \theta = \frac{\Delta r}{d} \quad \longrightarrow \quad \Delta r = d \sin \theta$$

This is a very useful result, that allows us to find the path difference from the distance between the sources and the angle to the detector.

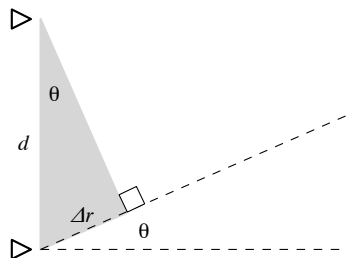

Combining this with our previous result, $\Delta r = m\frac{\lambda}{2}$, we find the

angles for the minima and maxima.

$$d \sin \theta_m = m \frac{\lambda}{2} \quad \begin{cases} \text{max} & m \text{ is even.} \\ \text{min} & m \text{ is odd} \end{cases}$$

▷ PROBLEM 7.10

You set up a sheet of aluminum foil to block a microwave transmitter. You now punch two holes in the foil, so that the microwaves pass through the holes. The holes are 10 cm apart. You now place a microwave detector on a track that is parallel to the foil and 3 meters away. By sliding the detector along the track you observe that the response of the detector is as shown in the diagram. What is the wavelength of the microwave?

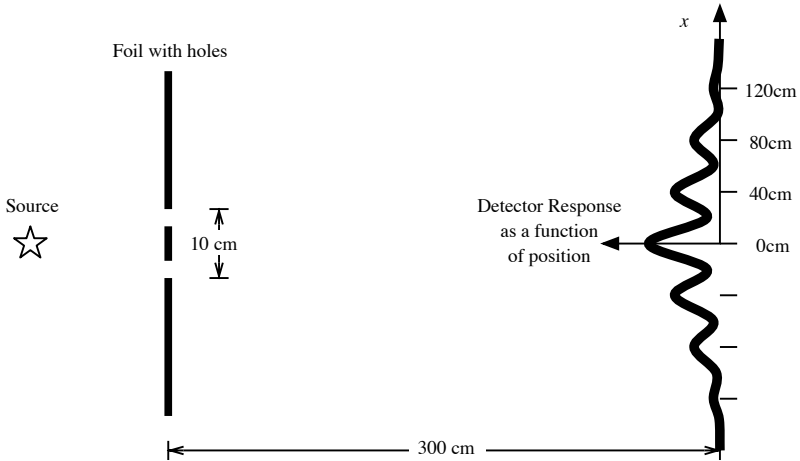

§ 7.9 Thin Film Interference

The swirling colors that you see reflected in a soap bubble and in puddles in a parking lot are a result of interference. Let us start by considering the colors in the puddles. The reason that you only see this in a parking lot is because it only happens when there is a thin film of oil on the top of the water. Consider the diagram to the right, of the layers of a puddle. At the bottom we have the pavement of the parking lot. Next there is the pool of water. On top of the water is a thin layer of oil. The thickness of the oil has been exaggerated so that we can see what is happening.

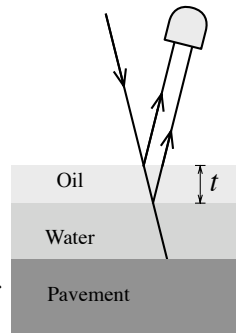

The light from the sun strikes the surface of the oil and some of it is reflected back toward the detector (your eye). The rest of the light

passes into the oil, where it proceeds until it reaches the water, at which point part of the light is reflected back toward the detector. The light that is not reflected passes into the water and eventually strikes the pavement, where it is mostly absorbed, since the pavement is black. In the end then, we have light from the sun reflected into the detector, by two paths, one path is reflected from the air-oil interface and the other path is reflected from the oil-water interface. If the light is nearly normal to the surface the path difference will be twice the thickness of the oil: $\Delta r = 2t$. The light will be strongly reflected when the two paths are in-phase, that is when $\Delta r = m\frac{\lambda}{2}$ with m even. Thus in order for the light to be strongly reflected we need,

$$2t = m\frac{\lambda}{2} \longrightarrow \lambda = \frac{4t}{m}$$

So only wavelengths that “match” the thickness of the oil will be reflected. This is why you see swirling colors, what you are seeing is the different thicknesses of the oil film, and for each thickness there is a particular color that gets reflected.

There are two complications to thin films that we need to consider.

The first complication is that the wavelength of light changes when it passes into the oil. This is because the light slows down in the oil.

Definition: Index of Refraction

The *index of refraction* of an optical medium is the ratio of the speed of light in a vacuum and the speed of light in the medium.

$$n = \frac{c}{v}$$

Let λ be the wavelength in a vacuum, then $\lambda f = c$. Let λ' be the wavelength in the medium, then $\lambda' f = v$. Taking the ratio of these two equations we find

$$\frac{\lambda f}{\lambda' f} = \frac{c}{v} = n$$

Solving for λ' we find the following result.

Theorem: Wavelength in a Medium

$$\lambda' = \frac{\lambda}{n}$$

The reason that we care the wavelength has changed, is that when we use the result that $\Delta r = m\frac{\lambda}{2}$ we need to use the wavelength where the path difference Δr occurs. In the case considered above, the extra bit of path occurs within the oil, so we need to use the wavelength in the oil.

In order to understand the root cause of the second complication, consider a soap bubble again. If you make a soap bubble and watch it carefully, you will notice that just before it pops, it appears that the top of the bubble has a hole in it. There is not actually a hole, but the top of the bubble looks like it has a hole because when the bubble gets very thin, no light is reflected from the surface of the bubble. Let us consider what our prediction would be for a very thin bubble. From our work with the oil film we expect that we will get a maximum reflection when $2t = m\lambda/2$, and m is even. Recall also that $m = 0$ gives a maximum, so $t \approx 0$ should give a maximum for all wavelengths. Thus we expect the soap bubble to reflect very well when the film of bubble juice gets very thin. The truth is just the opposite.

The key to this puzzle is to understand that when a wave is reflected it can be inverted, that is the direction of the displacement can be reversed. But a reversal is the same as a π phase shift.

Fact: Reflection Phase Shift

When a wave is reflected at an interface between two media there will be a π phase shift in the reflected wave if the index of refraction of the incident medium is lower than the index of refraction of the reflecting medium. If the incident medium has a higher index, there is no phase shift.

▷ PROBLEM 7.11

Explain using the reflection phase shift why a thin soap bubble reflects no light.

§ 7.10 Single Slit Diffraction

If a wave is passed through a rectangular hole that is much narrower in one direction than the other we find that we get an interference pattern like we do with a two source. Such a hole is usually referred to as a slit since it is so narrow in one direction.

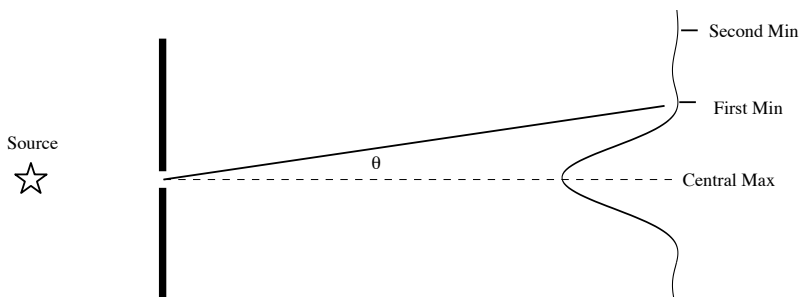

Fact: Single Slit Diffraction

If light is passed through a single slit of width a , then the angle between the central maximum and the first minimum is given by

$$a \sin \theta = \lambda$$

§ 7.11 Homework

▷ PROBLEM 7.12

A pair of speakers is configured as shown, with a microphone placed directly in front of one of the speakers. Sound waves having a wavelength 10 cm are coming from the speakers. The speakers are in phase with each other. What is the minimum distance d between the speakers so that no sound is heard at the microphone labeled P ?

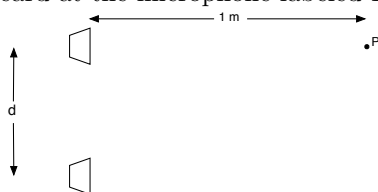

▷ PROBLEM 7.13

A material having an index of refraction of 1.30 is used to coat a piece of glass ($n = 1.50$). What should be the minimum thickness of this film to minimize reflection of 500nm light?

▷ PROBLEM 7.14

A soap bubble of index of refraction 1.33 strongly reflects both the red and the green components of white light. What film thickness allows this to happen? (In air, $\lambda_{\text{red}} = 700\text{nm}$, $\lambda_{\text{green}} = 500\text{nm}$.)

▷ PROBLEM 7.15

A beam of 560nm light passes through two closely spaced glass plates, as shown below. For what minimum nonzero value of the plate separation d is the transmitted power a maximum?

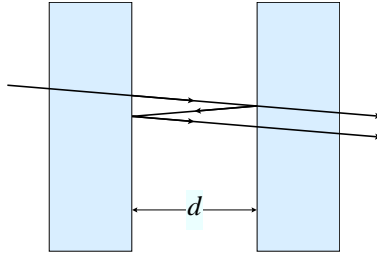

▷ PROBLEM 7.16

A pair of narrow parallel slits separated by 0.25mm is illuminated by green light ($\lambda = 546.2\text{nm}$). The interference pattern is observed on a screen 1.2m away from the plane of the slits. Calculate the distance from the central maximum to the first bright region on either side of the central maximum and between the first and second dark bands.

▷ PROBLEM 7.17

On a day when the speed of sound is $354\frac{\text{m}}{\text{s}}$, a 2000Hz sound wave impinges on two slits 30.0cm apart. At what angle is the first maximum located? If the sound wave is replaced by 3.00cm microwaves, what slit separation gives the same angle for the first maximum? If the slit separation is $1.00\mu\text{m}$, light of what frequency gives the same first maximum angle?

▷ PROBLEM 7.18

Two waves with amplitudes $y_1 = A \cos(\omega t - kd_1 + \delta)$ and $y_2 = A \cos(\omega t - kd_2)$ interfere with each other. Prove that the resultant amplitude, $y_1 + y_2 = y$ is

$$y = 2A \cos\left(\frac{k}{2}(d_2 - d_1) + \frac{\delta}{2}\right) \cos\left(\omega t - \frac{k}{2}(d_1 + d_2) + \frac{\delta}{2}\right)$$

Choose $d_1 = d_2 = 0$ and make plots of $y_1(t)$, $y_2(t)$, and $y(t)$ for $\delta = \pi/8$, $\pi/4$, $\pi/2$, and π .

▷ PROBLEM 7.19

Two slits are separated by a distance d . Light of wavelength λ comes from a far distant source and strikes the slits at an angle θ_1 as in the figure below. An interference maximum is formed on a screen that is far to the right of the slits. The maximum occurs at an angle θ_2 . Show that $\sin \theta_2 - \sin \theta_1 = m\lambda/d$, where m is an integer.

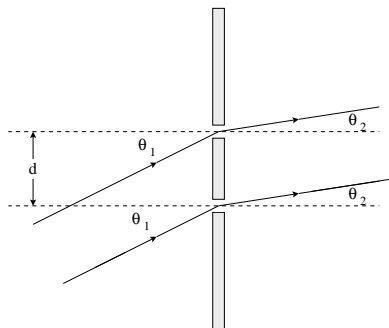

▷ PROBLEM 7.20

A material having an index of refraction of 1.30 is used to coat a piece of glass ($n = 1.50$). What should be the minimum thickness of this film to minimize reflection of 500nm light?

▷ PROBLEM 7.21

A soap bubble of index of refraction 1.33 strongly reflects both the red and the green components of white light. What film thickness allows this to happen? (In air, $\lambda_{red} = 700\text{nm}$, $\lambda_{green} = 500\text{nm}$.)

▷ PROBLEM 7.22

Light of wavelength 600 nm is used to illuminate, at near zero angle of incidence, two glass plates that are stacked on top of each other. At one end the plates are separated slightly because a wire has been placed between them on this end. The wire is 0.5 mm in diameter. How many bright fringes appear along the total length of the plates, when the plates are viewed from the same side as the light source?

▷ PROBLEM 7.23

The double slit equation $d \sin \theta = m\lambda$ and the equation for a single slit $a \sin \theta = m\lambda$ are sometimes confused. For each equation, define the symbols and explain the equation's application.

▷ PROBLEM 7.24

Light from a He-Ne laser ($\lambda = 632.8\text{nm}$) is incident on a single slit. What is the minimum width for which no diffraction minima are observed?

▷ PROBLEM 7.25

A screen is placed 50cm from a single slit, which is illuminated with 690nm light. If the distance between the first and third minima in the diffraction pattern is 3.0mm, what is the width of the slit?

▷ PROBLEM 7.26

Light from an argon laser strikes a diffraction grating that has 5310 lines/cm. The central and first order principal maximum are separated

by 0.488 m on a wall that is 1.72 m from the grating. Determine the wavelength of the laser light.

▷ PROBLEM 7.27

Paul Revere received information from a person in a church steeple that was 1.8 miles away, by the number of lanterns that were displayed: "One if by land and, two if by sea." What would be the minimum separation between two lantern for Paul Revere to be able to distinguish them? Assume that the diameter of his pupils was 4.00mm and that the light had a wavelength of about 580nm.

▷ PROBLEM 7.28

Redo all the problems in the book starting from chapter 1, but add one to each constant. Add all of the numerical answers and subtract 1 for each non numerical answer. What number do you get?

§ 7.12 Summary

Definitions

- Index of refraction: $n = \frac{c}{v}$

Theorems

- A traveling sinusoidal wave can be represented by

$$y = A \cos(\omega t - kx)$$

where $\omega = \frac{2\pi}{T}$ and $k = \frac{2\pi}{\lambda}$.

- For a traveling wave: $\lambda f = v$.
- Interference of two waves: If two waves are added together with powers P_1 and P_2 then the resultant power is

$$P = P_1 + P_2 + 2\sqrt{P_1 P_2} \cos(\phi_2 - \phi_1)$$

- Maxima and minima of the power occur when $\Delta\phi = \phi_2 - \phi_1$ is an even and odd multiple of π , respectively.
- The phase difference due to a path difference is $\Delta\phi_{\text{path}} = 2\pi \frac{\Delta r}{\lambda}$
- If a field point is far from two sources a distance d apart then the path difference is $\Delta r = d \sin \theta$ where θ is the angle between the path to the field point and the normal to the line connecting the two sources.
- When a wave is reflected at an interface between two media there will be a π phase shift in the reflected wave if the index of refraction of the incident medium is lower than the that of the reflecting medium.
- The wave length in a medium is longer than in a vacuum: $\lambda' = \frac{\lambda}{n}$
- If light is passed through a single slit of width a , then the angle between the central maximum and the first minimum is given by,

$$a \sin \theta = \lambda$$

8

Geometric Optics

§ 8.1 Short Wavelength Limit

In the last section we saw the wave nature of light in the sections where we considered interference. In many situations these interference effects are small enough to be ignored. For example if light comes in through two windows in your house you will not find an unexpected dark spots in the room where the light from the two windows combines.

Fact: Short Wavelength Limit

When the wavelength of the light is much shorter than the size of the objects that the light is traveling through, then the wave nature of the light can be ignored.

For example if you set up a candle and cast shadow of your hand on the wall, the shadow is a faithful replica of your hand, there is no interference pattern developed because of the interference between the light going between different fingers.

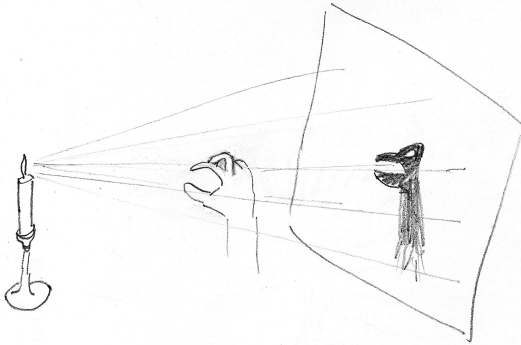

In this short wavelength limit we can think of a light source as sending out rays of light that continue in a straight line unless something stops them. Because of this use of straight lines, this way of dealing with light is called Geometric Optics or Ray Optics.

▷ PROBLEM 8.1

In the photograph below (by Colleen Pinski) can be seen a person, the sun and the moon. Estimate the distance between the camera that took the photo by assuming a height for the person and using the know diameter of and distance to the moon.



§ 8.2 Reflection

Now consider what happens when a ray of light strikes a mirror.

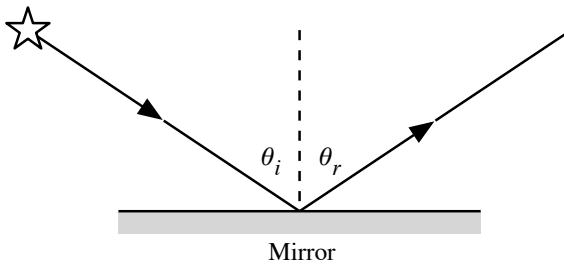

Fact: Law of reflection

The incident and reflected angles are the same.

$$\theta_i = \theta_r$$

§ 8.3 Virtual Image

Let us draw some of the other rays that come from the source.

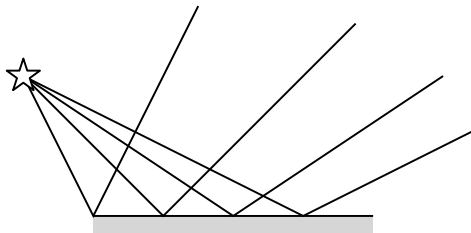

Notice that each ray obeys the law of reflection. This may look a little confusing, but if we trace the reflected ray back through the mirror, we see that they all converge on the same point.

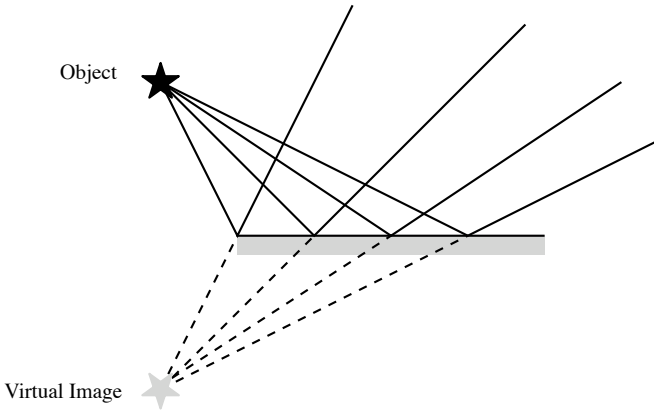

We see then that from the point of view of an observer of the reflected rays, it appears that the object is really behind the mirror, because all of the rays appear to come from that one point. Our brain makes the simplest conclusions and assumes that the rays come in a straight line, not in the bent line that they actually followed.

This type of image is called a virtual image of the object since the light does not actually come from the image. We will see later, ways in which it is possible to construct a real image.

§ 8.4 Snell's Law

When a ray of light strikes an interface between two different media, some of the light is reflected, and some of the light is transmitted through the interface.

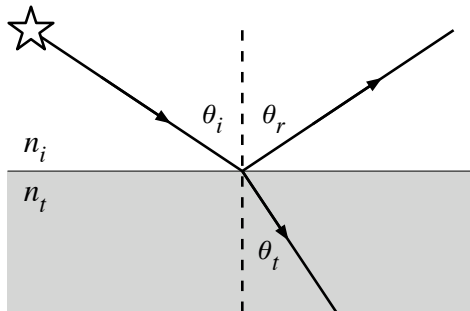

Note that both the reflected and transmitted beams are deflected from their original direction. The angle at which the transmitted ray leaves the interface is given by Snell's Law.

Fact: Snell's Law

$$n_t \sin \theta_t = n_i \sin \theta_i$$

We can use Snell's law to explain a strange phenomenon that you may have noticed. If you view a fish tank from the corner, you can see objects in the tank through the front glass and the side glass at the same time. This is because of the bending of the light when it leaves the water. The effect is depicted in the diagram below.

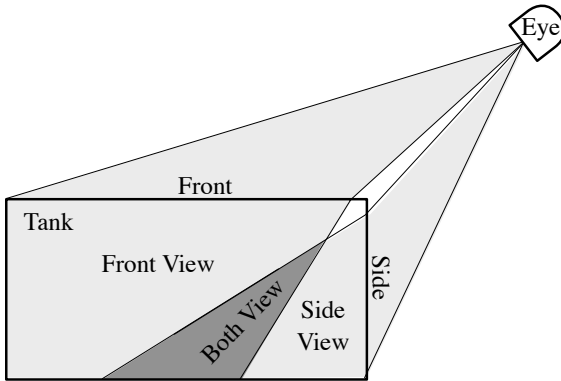

The dark grey region is the part of the tank that can be seen from both the front and the side. You can actually see around the corner. This is really weird. So if you want a wider view from your window, you could just fill your room with water. Remember to also install the air tanks.

§ 8.5 Virtual Image Caused by Refraction

Consider a shiny coin on the bottom of a swimming pool.

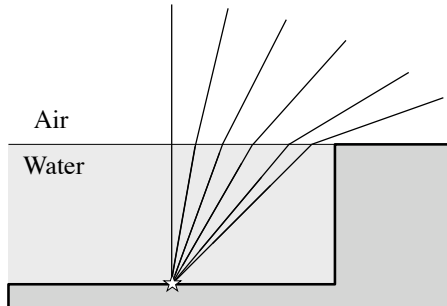

The light comes up from the coin and out into the air. When the light comes out it spreads out more. This looks similar to the rays reflected

from a mirror. This similarity leads one to wonder if there is a virtual image of the coin, that is, is there a place where all the rays appear to originate. The following diagram traces the rays back into the water.

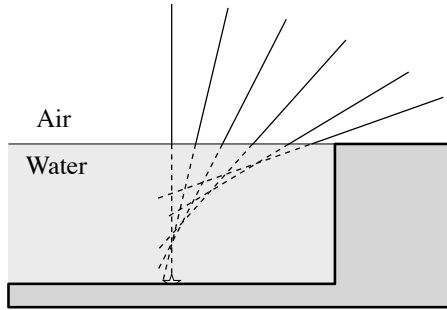

We see that they do not converge on a single point. The location of the image changes as you view it from different angles. When you get down low and view it from near the horizon the image is close to the surface of the water and also displaced horizontally from the object. As you move your view point upward the image moves away from you and deeper into the water. When you view from straight overhead the image is directly over the object and about $1/5$ of the way up toward the surface.

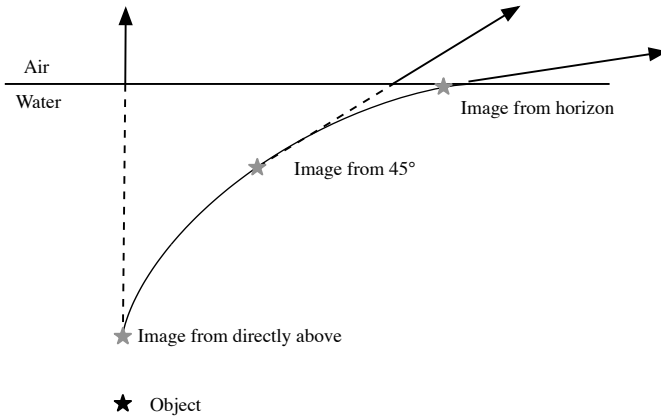

This is very different from the image in a flat mirror. The image in a flat mirror is in the same position, from any viewpoint in the room.

▷ PROBLEM 8.2

Consider the beam of light shown going through a prism made of glass with an index of refraction n .

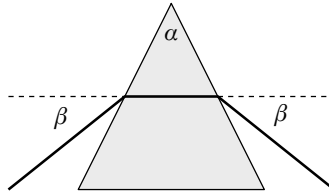

Show that the net deflection of the beam (2β) is

$$2\beta = 2 \arcsin(n \sin \frac{\alpha}{2}) - \alpha$$

§ 8.6 Thin Lens Equation

Imagine that we take a stack of prisms as shown in the diagram. Since the prisms farther from the middle have a steeper angle they bend the light ray more sharply. If we pick the angle of each prism correctly all of the rays will converge on the same point.

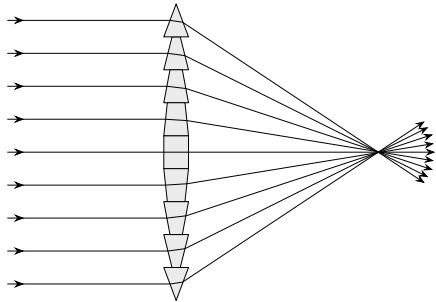

Such a device was used in old light houses in order to focus the light on the horizon (where there are ships that want to see the light) rather than letting it spread out and go into the water or into the sky.

Now imagine that you make the prisms in the middle thicker, without changing the angle of the faces. We would now end up with a smooth curved surface. Since the angle of faces was not changed the light would still converge on the single point. You can see that you get a lens. This type of lens is called a *converging lens*, since it bends the rays toward each other.

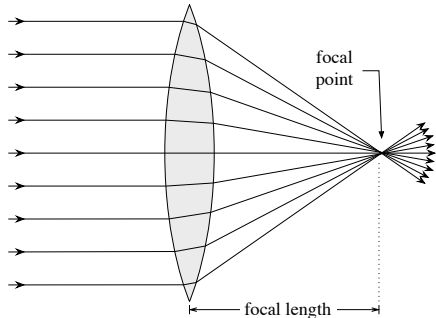

The *optical axis* of the lens is a line that passes through the center of the lens, that is normal to the surface of the lens. A *focus* is a point where rays converge. The focus of rays that are parallel to the optical axis is called the *principle focus* or *focal point*. The distance between the lens and the focal point is called the *focal length* of the lens.

Suppose that you set up your lens at sunrise, so that the rays are parallel to the optical axis and converge at the focal point. If you come

back in an hour the sun will have moved up in the sky, and the rays will no longer be parallel to the optical axis. The rays will still converge at a point but it will not be the focal point of the lens. The new focus will be in the *focal plane*, a plane parallel to the plane of the lens and one focal length away from the lens.

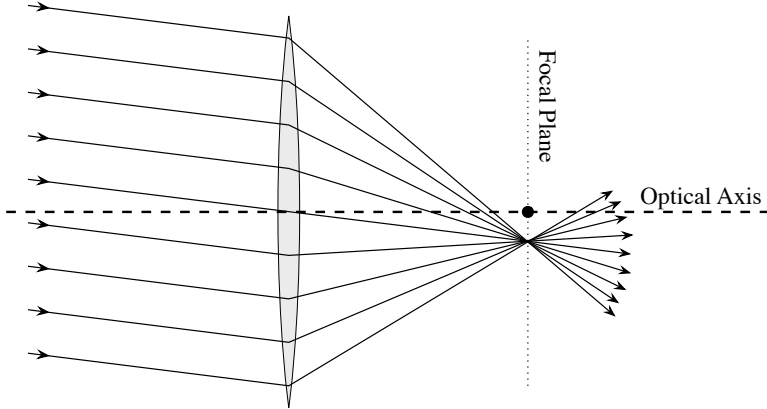

Notice that the ray that passes through the center of the lens is not deflected. This is a particularly nice ray for doing constructions of images, as we will see. In this case it allows us to find the location of the focus, since the focus is at the intersection of this straight line and the focal plane. Once we have found the focus, using the central ray, we can draw the other rays, because they must pass through the focus also.

We can also reverse these diagrams: Light that comes from a point in the focal plane and strikes the lens travels parallel to the ray that passes through the center of the lens.

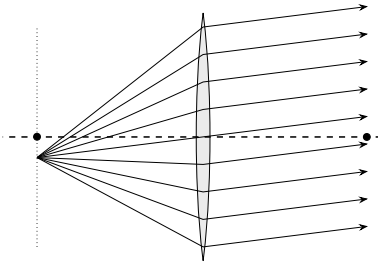

We have seen what happens to groups of rays that are parallel to each other. Let us now see what happens to groups of rays that diverge from a point that is not in the focal plane. Suppose that you have light radiating from a point. The point is indicated by the fat arrow on the left, in the following diagram. We follow the light from this point source to its focus.

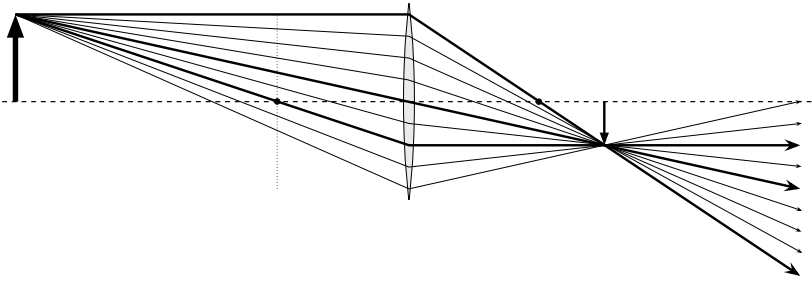

In the diagram we are able to draw the three rays that are bolded, because they are, (top ray) parallel to the optical axis, (middle ray) through the center, and (bottom ray) through the focal point. These three rays are called the *principle rays*. From the three principle rays (we only needed two really) the location of the focus is determined. After the location of the focus is determined, the other faint rays are drawn so that they go through the focus.

Notice that the rays of light actually do pass through the focus. If we place a piece of paper at that point the paper would be illuminated. This type of image is called a *real image*.

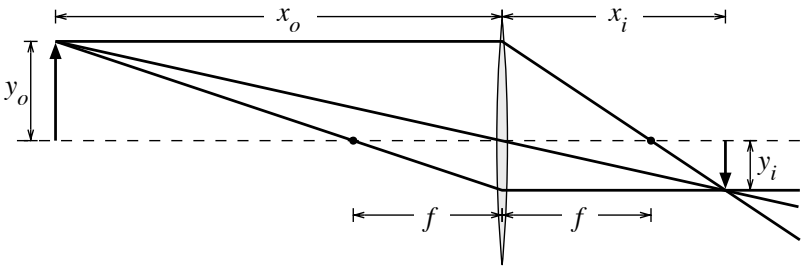

The location and size of the image can be computed from the location and size of the object.

Theorem: Thin Lens Equations

With the dimensions as shown in the figure above,

$$\frac{1}{x_o} + \frac{1}{x_i} = \frac{1}{f}$$

Theorem: Magnification Equations

With the dimensions as shown in the figure above,

$$\frac{x_o}{y_o} = -\frac{x_i}{y_i}$$

where y is negative if below the optical axis.

▷ PROBLEM 8.3

Using geometric arguments, prove the thin lens equations.

▷ PROBLEM 8.4

You have a lens with a focal length of 100cm. You place an object at 150cm from the lens. The object is 3cm tall.

- Construct the image location using the principle rays.
- Find the location of the image using the thin lens equation.
- Find the height of the image from the magnification equation.

§ 8.7 Virtual Image in a Converging Lens

You do not get a real image for all positions of the object. When the object distance is smaller than the focal length, you get a virtual image. You have probably noticed this effect before while using a magnifying glass: if you look at something far away through a magnifying glass, you will see the object upside down. If you move closer to the object at some point it flips over and appears right side up.

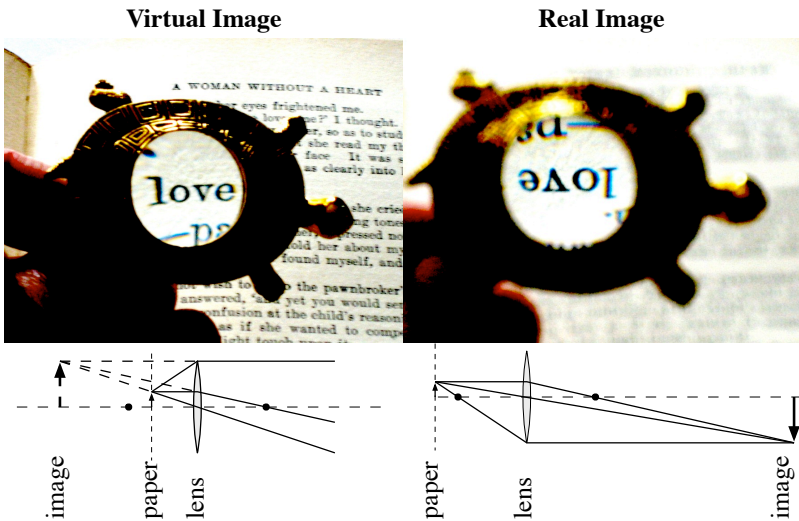

In the photograph above you can notice a few things. In the photo on the left, the letters on the page are almost in-focus, this means that the image is not too far from the page. In contrast, in the photo on the right, the letters on the page are very out of focus, this tells us that the image is far from the page. This is verified by the ray diagrams.

Here is a larger diagram, showing the construction of the virtual image, that corresponds to the photo on the left.

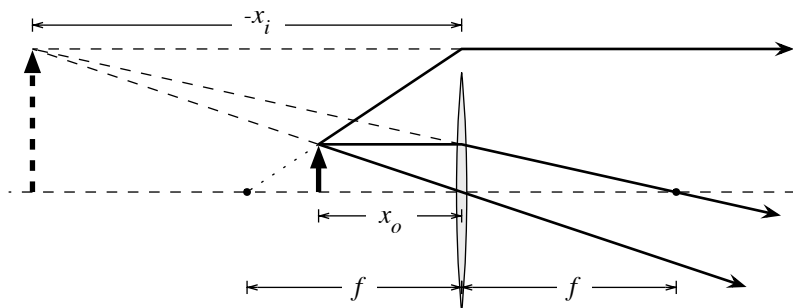

Notice that we still use the three principle rays. The topmost ray in the figure above strikes the lens as if it came from the focal point. The dotted line going back to the focal point is an extension of the actual path of the light ray. Notice also that even though the ray constructed in this manner does not hit the lens (since the lens was not tall enough) we can still use the ray to construct the location of the image.

The thin lens and magnification equations can still be used in this case, but in order to get the algebra to work out correctly you need to interpret a negative image distance (x_i) as being on the side of the lens where the light originates from.

EXAMPLE Suppose that in the figure above $x_o = 6\text{cm}$, $y_o = 2.0\text{cm}$ and $f = 9\text{cm}$. Putting this into the thin lens equation we find

$$\begin{aligned} \frac{1}{6\text{cm}} + \frac{1}{x_i} &= \frac{1}{9\text{cm}} \longrightarrow \frac{1}{x_i} = \frac{1}{9\text{cm}} - \frac{1}{6\text{cm}} = -\frac{1}{18\text{cm}} \\ &\longrightarrow x_i = -18\text{cm} \end{aligned}$$

Now we can use the magnification equation to find the size of the image.

$$\frac{y_i}{x_i} = -\frac{y_o}{x_o} \longrightarrow y_i = -\frac{x_i}{x_o}y_o = -\frac{-18}{6}(2\text{cm}) = 6.0\text{cm}$$

▷ **PROBLEM 8.5**

You have a lens with a focal length of 80cm. You place an object at 60cm from the lens. The object is 3cm tall.

- Construct the image location using the principle rays.
- Find the location of the image using the thin lens equation.
- Find the height of the image from the magnification equation.

▷ **PROBLEM 8.6**

For a converging lens with a focal length of f , over what range of object distances is the image:

- real?

- (b) virtual?
- (c) upright?
- (d) inverted?
- (e) larger than the object?

§ 8.8 Diverging Lenses

Now consider what happens when parallel rays strike a lens that is thinner in the middle. The rays diverge from the optical axis as if they came from the focal point on the incident side. This type of lens is called a *Diverging Lens*. This is drawn in the figure below.

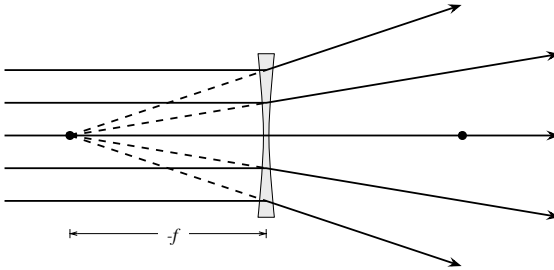

We might also consider what happens to rays that are converging toward the focal point on the far side of the lens, these rays exit the lens parallel to the optical axis, as indicated in the diagram below.

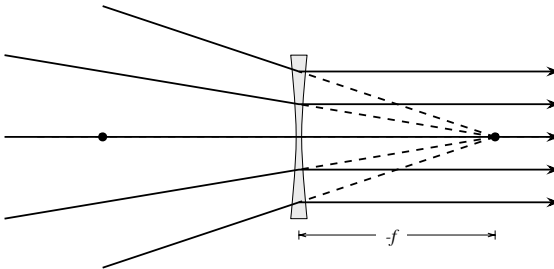

We can, as before, construct the location and size of the image, by using three principle rays. The three rays are, (1) a ray that leaves the object parallel to the optical axis, (2) a ray going through the center of the lens, (3) a ray that leaves the object headed toward the focal point on the far side of the lens. This has been done in the figure below.

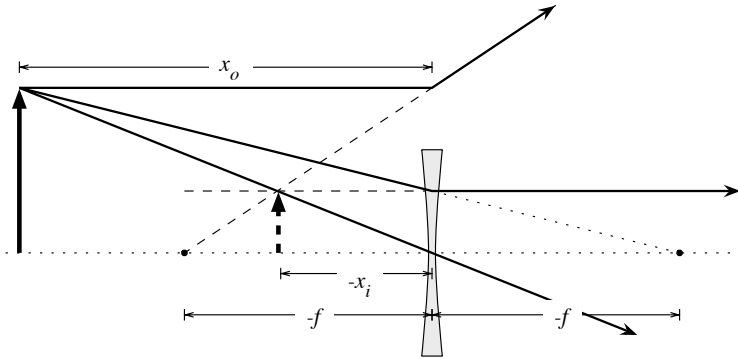

We can also find the location and size of the image by using the thin lens equation and the magnification equation. Once again a negative value for image distance x_i , indicates that the image is on the same side of the lens as the source of the light. We must also use a negative value for the focal length of a diverging lens.

EXAMPLE

Suppose that in the figure above $x_o = 20\text{cm}$, $y_o = 8\text{cm}$ and $f = -12\text{cm}$. Putting this into the thin lens equation we find

$$\begin{aligned} \frac{1}{20\text{cm}} + \frac{1}{x_i} &= \frac{1}{-12\text{cm}} \longrightarrow \frac{1}{x_i} = -\frac{1}{12\text{cm}} - \frac{1}{20\text{cm}} \\ &\longrightarrow x_i = -7.5\text{cm} \end{aligned}$$

Now we can use the magnification equation to find the size of the image.

$$\frac{y_i}{x_i} = -\frac{y_o}{x_o} \longrightarrow y_i = -\frac{x_i}{x_o} y_o = -\frac{-7.5}{20}(8\text{cm}) = 3.0\text{cm}$$

▷ PROBLEM 8.7

You have a lens with a focal length of -100cm . You place an object at 150cm from the lens. The object is 5cm tall.

- Construct the image location using the principle rays.
- Find the location of the image using the thin lens equation.
- Find the height of the image from the magnification equation.

▷ PROBLEM 8.8

For a diverging lens, show that the object distance must be negative, in order for the image distance to be positive. In other words the object must be virtual, in order for the image to be real. We will see, in the next section, how it is possible for to have a virtual object to be negative.

§ 8.9 Sign Conventions and Coordinates System

We have used the coordinates (x_o, y_o) for the object and the coordinates (x_i, y_i) for the image. The direction of positive y is the same for both coordinate systems. The direction of positive x was opposite.

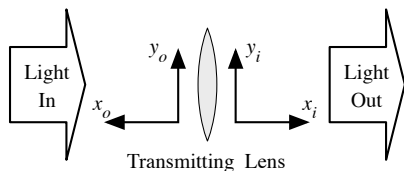

A curved mirror is also a lens. The coordinate sign convention, stated as follows, covers both types of lenses.

- The x -axis of the object coordinate system is in the opposite direction as the incoming light.
- The x -axis of the image coordinate system is in the same direction as the outgoing light.

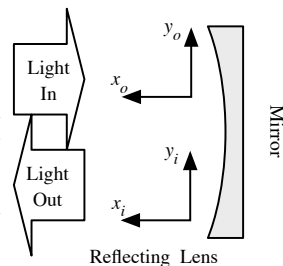

A concave mirror (as shown) is a converging lens, while a convex mirror is a diverging lens. The sign convention for focal lengths is the same for mirrors.

§ 8.10 Multi-Lens Optical Systems

Most optical systems are composed of more than one lens. We do not need more theory in order to work with a multi-lens system. The light passes from one lens to the next in sequence. In order to do a computation with a multi-lens system, we need only use the image of one lens as the object of the next lens.

EXAMPLE Suppose that you have a diverging lens, $f = -12\text{cm}$, followed by a converging lens, $f' = 16\text{cm}$. The lenses are 20 cm apart. You place an object that is 9cm tall at a distance of 24 cm from the diverging lens. We can construct the final image as follows.

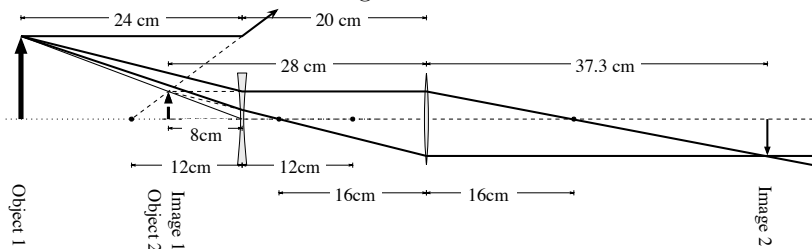

Or we could compute the final image from the thin lens equation. Given $f = -12\text{cm}$ and $x_o = 24\text{cm}$ we can compute

$$\frac{1}{x_i} = \frac{1}{f} - \frac{1}{x_o} = \frac{1}{-12\text{cm}} - \frac{1}{24\text{cm}} = -\frac{3}{24\text{cm}} \rightarrow x_i = -8\text{cm}$$

So

$$y_i = -\frac{x_i}{x_o}y_o = -\frac{-8}{24}(9\text{cm}) = 3\text{cm}$$

The second lens is 20 cm past the first, so the object distance for the second lens is

$$x'_o = 20\text{cm} - x_i = 20\text{cm} - (-8\text{cm}) = 28\text{cm}.$$

From this we can compute the final image location

$$\frac{1}{x'_i} = \frac{1}{f'} - \frac{1}{x'_o} = \frac{1}{16\text{cm}} - \frac{1}{28\text{cm}} \rightarrow x'_i = 37.33\text{cm}$$

and

$$y'_i = -\frac{x'_i}{x'_o}y_o = -\frac{-37.3}{28}(3\text{cm}) = 4\text{cm}$$

Notice that the second lens has formed a real image of the virtual image produced by the first lens.

In the following example, the second lens has a virtual object.

EXAMPLE Suppose that you have a converging lens, $f = 12\text{cm}$, followed by a diverging lens, $f' = -12\text{cm}$. The lenses are 18 cm apart. You place an object that is 4cm tall at a distance of 24 cm from the converging lens. We can construct the final image as follows.

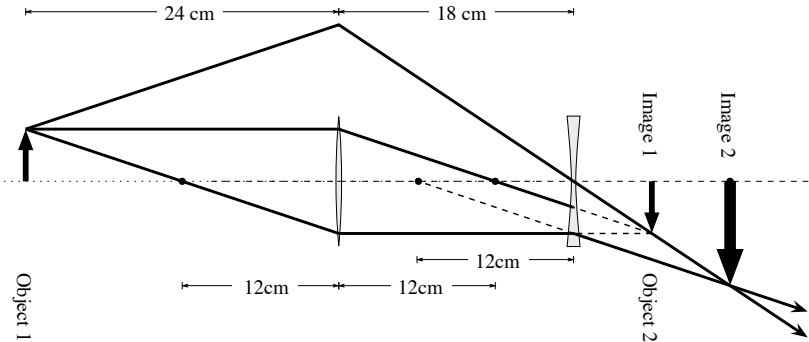

The top ray is not used to construct the first image, since it is not a principle ray of the first lens. The first image is constructed from the other two rays, and then the third ray is drawn so that it goes to the first image and also through the center of the second lens, this makes it a principle ray of the second lens. Similarly the center ray is not a principle ray of the second lens, it is only used for constructing the first image. The bottom ray is a principle ray of both lenses.

We can also compute the final image from the thin lens equation. Given $f = 12\text{cm}$ and $x_o = 24\text{cm}$ we can compute

$$\frac{1}{x_i} = \frac{1}{f} - \frac{1}{x_o} = \frac{1}{12\text{cm}} - \frac{1}{24\text{cm}} = \frac{1}{24\text{cm}} \quad \longrightarrow \quad x_i = 24\text{cm}$$

So

$$y_i = -\frac{x_i}{x_o} y_o = -\frac{24}{24}(4\text{cm}) = -4\text{cm}$$

The second lens is 18 cm past the first, so the object distance for the second lens is

$$x'_o = 18\text{cm} - x_i = 18\text{cm} - (24\text{cm}) = -6\text{cm}.$$

From this we can compute the final image location

$$\frac{1}{x'_i} = \frac{1}{f'} - \frac{1}{x'_o} = \frac{1}{-12\text{cm}} - \frac{1}{-6\text{cm}} \quad \longrightarrow \quad x'_i = 12\text{cm}$$

and

$$y'_i = -\frac{x'_i}{x'_o} y_o = -\frac{12}{-6}(-4\text{cm}) = -8\text{cm}$$

Notice that the diverging lens has formed a real image. Also notice that the first lens would have formed a real image, but since the diverging lens enters the optical path before the image is formed, the first image does not actually get formed.

§ 8.11 Homework

▷ PROBLEM 8.9

You are designing a movie projector. The film is 8mm wide, and you wish to project this film onto a screen that is 2.0 meters wide from a distance of 10 meters.

- How far from the lens should the film be?
- What should the focal length of the lens be?

▷ PROBLEM 8.10

An object is located 20cm to the left of a diverging lens having a focal length $f = -32\text{cm}$. Determine the location and magnification of the image. Construct a ray diagram for this arrangement.

▷ PROBLEM 8.11

An object is placed 40 cm in front of a lens with focal length +10 cm. Describe the image (i.e. location, magnification, etc.).

▷ PROBLEM 8.12

Two converging lenses, each of focal length 10 cm, are separated by 35 cm. An object is 20 cm to the left of the first lens. (a) Find the

position of the final image using both a ray diagram and the thin-lens equation. (b) Is the image real or virtual? Upright or inverted? (c) What is the overall magnification of the image?

▷ PROBLEM 8.13

An object is 15 cm in front of a positive lens of focal length 15 cm. A second negative lens of focal length -15 cm is 20 cm from the first lens. Find the final image and draw a ray diagram.

▷ PROBLEM 8.14

A concave mirror has a focal length of 40.0 cm. Determine the object position for which the resulting image is upright and four times the size of the object.

▷ PROBLEM 8.15

A concave mirror has a radius of curvature of 60 cm, ($f = 30$ cm). Calculate the image position and magnification of an object placed in front of the mirror at distances of 90 cm and 20 cm. Draw ray diagrams to obtain the image in each case.

▷ PROBLEM 8.16

Under what conditions will a concave mirror produce an erect image? A virtual image? An image smaller than the object? An image larger than the object? Repeat the exercise for a convex mirror.

▷ PROBLEM 8.17

A dentist wants a small mirror that will produce an upright image with a magnification of 5.5 when the mirror is located 2.1 cm from a tooth. (a) What should the radius of curvature of the mirror be? (b) Should it be concave or convex?

§ 8.12 Summary

Facts

- Law of Reflection:

$$\theta_i = \theta_r$$

- Snell's Law:

$$n_i \sin \theta_i = n_t \sin \theta_t$$

Theorems

- Thin Lens Equation:

$$\frac{1}{x_o} + \frac{1}{x_i} = \frac{1}{f}$$

A

Hints

1.1 Do the directions “by hand”. To make it easier to keep track of everything write all forces in terms of the quantity $F_0 = \frac{q^2}{4\pi\epsilon_0 a^2}$.

1.2 Use the vector form of Coulomb’s law.

1.3 The answer is $\vec{E}(x, 0) = \frac{q}{4\pi\epsilon_0} \frac{-2a\hat{j}}{(x^2+a^2)^{3/2}}$.

1.4 Use polar coordinates, $\vec{r}_s = R \cos \theta \hat{i} + R \sin \theta \hat{j}$ and $dq = \frac{Q}{2\pi} d\theta$.

1.5 Use Gauss’s Law.

1.6 Do not attempt to integrate the flux over the surfaces. First, look carefully at the orientation of the electric field through each of the three faces that touch the charge. Second, because of the symmetry of the configuration the remaining three faces must have the same flux as each other. Third, notice that if you placed eight such cubes around the charge (forming a larger cube with the charge at the center), that all eight smaller cubes would have the same flux.

1.7 Use a gaussian surface that is a sphere of radius r , centered on the charge.

1.8 Use Gauss’s law. The gaussian surfaces are spheres. If $r < R$ then the amount of charge inside the gaussian surface depends on r , show that the amount of charge inside is $q_{\text{in}} = Q \frac{r^3}{R^3}$

1.10 Assume that the field is directed straight out from the line. Let the Gaussian surface be a cylinder (like a tin can) with the line charge as the axis of the cylinder. Note that the flux through the ends of the can is zero because of the orientation relative to the field.

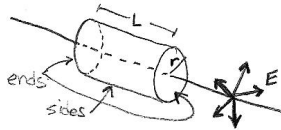

1.11 The gaussian surface is a cylinder of radius r and length L .

1.12 Recall that there can be no field inside the body of a conductor that is in static equilibrium.

1.13 The geometry gives you the angle of the forces, but because the charges are not of the same size you must still deal with both components. Depending on your disposition, you might prefer using the vector form of Coulombs law.

1.14 Since this is only an estimate, assume that you are composed entirely of water.

1.16 Be sure to add the parts as vectors.

1.17 Let the charge elements dq be little sections of arc that subtend an angle $d\theta$. Notice that the full charge is spread over a half a circle so that the charge density (charge per angle) is $\frac{-7.5\mu\text{C}}{\pi}$, so that $dq = \frac{-7.5\mu\text{C}}{\pi}d\theta$.

1.18 Use the work energy theorem. Recall that work is force times distance.

1.19 This is like a projectile motion problem, but this time we have a constant electric force rather than a constant gravitational force.

1.20 Start by making a free body diagram and be sure to include the force of gravity and the force of the string.

1.21 A flux is negative if it is into the volume of the box and positive if the flux is out of the volume of the box.

1.22 There is a very easy way to do this problem, by using the fact that there is no charge inside the volume of the nose cone.

1.25 $\vec{r} = -x\hat{i}$

2.1 Look at the definition of electric potential, how is the electric potential related to potential energy?

2.2 Use the work energy theorem.

2.3 Follow the example in the text for a nonuniform field.

2.4 Follow the example in the text.

2.6 Consider a closed surface that is totally within the outer conductor and surrounds the inside surface of the outer conductor, as indicated by the dotted line in the figure. Using the fact that there is no field inside a conductor argue that the electric flux through this surface is zero. From this use Gauss's law to find the charge on the inside surface of the outer conductor. Next use the fact that the total charge on the outer conductor is equal to the sum of the charge on its two surfaces, to find the charge on the outside surface of the outer conductor.

2.7 Use Gauss's law. Remember that the electric field is zero inside the body of a conductor.

2.8 Use the definition of capacitance.

2.9 Use the fact that the electric field strength between the plates is both σ/ϵ_0 and $\Delta V/d$, where σ is the charge density on the plates.

2.10 Assume that the capacitor is charged so that the inside sphere has a charge Q and the outside sphere has a charge $-Q$. Use Gauss's law to get the field strength between the shells.

2.11 First suppose that there is a charge Q on the length L of the central wire, and a charge $-Q$ on the outer shield. Then use Gauss's law to show that the electric field strength between the wire and shield is $E = \frac{Q}{2\pi L\epsilon_0 r}$. Next show that the potential difference between the wire and shield is $\Delta V = \frac{Q}{2\pi L\epsilon_0} \ln(b/a)$. Finally use the definition of capacitance.

2.12 The field around a line charge has already been found, use this to find the electric potential around a single wire. Find the electric potential difference as you move from one to the other for each wire and then add. Once you have the electric potential difference between the wires you can find the capacitance.

2.13 Since there is a maximum field strength there is also a maximum energy density, and the energy density is the energy stored divided by the volume of the capacitor.

2.14 The change in the charge switches the direction of the electric field, which alters the dot product. Also $q = -|q|$.

2.15 Use the work energy theorem.

2.16 Use the work energy theorem.

2.17 Use the work energy theorem.

2.18 Use the work energy theorem.

2.19 Use the work energy theorem.

2.20 Assemble the particles one at a time. The work to bring the first particle in is zero since there is no field to do work against. The second particle feels the potential of the first as you bring it in. The third particle feels the potential of the first two, and so on.

2.21 The field is the gradient of the potential.

2.22
$$V = \int \frac{dq}{4\pi\epsilon_0 r}.$$

2.23 Find the electric potential for each section first. You have actually done a problem like each of the sections before.

2.24 Write out the field and electric potential of a point charge, then do some algebra.

2.25 The potential is the sum of the three point potentials. The field can be found from the derivative of the potential.

2.26 The answer will be in terms of the radius (r_0), field (E_0), charge density (σ_0), and potential (V_0) of the original drops. The charge is all on the surface of the drop.

2.27 Imagine that you build of the charge slowly. Suppose that you have already got a charge q accumulated and you want to bring in an amount dq more. How much work dW must you do? Once you have dW written out you can integrate to get W .

2.28 Use Gauss's law to find the field in all three regions. Then integrate from infinity inward to find the electric potential. You will need to split the integral into three regions because the form of the field changes each time you cross the surface of a shell.

2.29 Look at the definition of capacitance.

2.30 Look at the definition of capacitance.

3.1 The amount of charge is equal to the number of particles times the charge per particle.

3.2 You will need to use Ohm's law, the definition of current density and the relationship between the electric field and the electric potential $\Delta V = -E \Delta x$.

3.3 Use the result that $R = \rho L/A$.

3.4 Use $P = I \Delta V$.

3.5 Look up the theorem on electrical power.

3.6 Use the result of the example before this problem.

3.7 The current and voltage on the resistor can be negative (and they are in this case).

3.8 Assume that the centripetal acceleration of the electron is caused by the Coulomb force of the proton on the electron. Remember the definition of electric current.

3.9 Remember that you know the charge of each electron, and that current is the amount of charge per time.

3.10 Read the definition of current.

3.11 $q = \int dq = \int \frac{dq}{dt} dt$

3.12 First compute how many electrons pass a particular point in the wire in one second. All of these electrons together fill a volume V of the wire. From the number of electrons you can compute the volume of electrons. Once you have the volume you can compute the length the electrons occupy in the wire, since you know the cross sectional area of the wire. But this length is the distance the electrons move in one second.

3.13 Use the result that $R = \rho \ell/A$.

3.14 Look up electric power.

- 3.16** Compute the total charge that can flow from the battery. One kilowatt hour is a unit of energy 3600kJ.
- 3.17** From the specific heat of water you can find the energy required and from this you can find the power and thus from the known voltage you can find the current and then resistance.
- 3.18** The internal resistance acts like it is in series with the external resistor and an ideal voltage source.
- 3.19** Reduce the system in stages. Look for pairs of resistors in the system that are in parallel or in series, combine this pair, then repeat until there is only one resistor left.
- 3.23** Write out all of the equations and then solve.
- 3.25** Connect the circuit to a voltage supply V_S and using Kirchhoff's rules for the resultant circuit you can find the charge on each capacitor. This will in turn allow you to compute the total charge drawn from the power supply and thus the effective capacitance of the system.
- 3.26** Use Kirchhoff's rules
- 3.27** Use Kirchhoff's rules
- 3.28** The bulb that draws the most power is brighter.
- 3.29** The appliances are connected in parallel to the voltage supply.
- 3.30** Use the result of the other problem in which you computed the resistance of a 12 gauge copper wire.
- 3.31** The amount of heating is proportional to the power dissipated by the wire per length.
- 3.32** When the capacitor is fully charged, no current flows into it.
- 4.1**
- (a) Notice that $d\vec{\ell}$ has length $Rd\theta$ and is perpendicular to the radius vector.
- 4.2** Compute the force on each of the four sections of wire first. Recall that torque is $\vec{\tau} = \vec{r} \times \vec{F}$, where \vec{r} points from the axis of rotation to the point at which the force is applied.
- 4.5** For any radius it will take a time $2\pi m/qB$
- 4.6** Plug the given values into the Lorentz force formula and do the cross product.
- 4.7** The magnetic field of the earth points roughly northward.
- 4.8** Don't forget that the electron is negatively charged.
- 4.9** This question is asking you to relate acceleration and force so start with Newton's second law.

4.12 Consider the vector nature of the definition of work and the direction of the velocity relative to the magnetic force.

4.13 Write out the vectors \vec{L} for each line segment and then do the cross products.

5.1 Try plotting points for various values of t to get a sense of the function.

5.2 Start with $\vec{r}(t) = \vec{a} + bt\hat{i} + ct^2\hat{j}$ and find the value of the constants by demanding that the curve goes through the three given points.

5.3 The parameterization is $t\hat{i}$

5.4 The parameterization is $a \cos t\hat{i} + a \sin t\hat{j}$.

5.5 Since the current density is not uniform, $I_{\text{in}} = \int JdA$.

5.7 Use the result $B = \mu_0 I / 2\pi r$.

5.8 Use the Biot-Savart law.

5.9 Use the method of the previous problem, and also note that the current can be found from the electron speed and the radius of the orbit.

5.10 First argue that half of the wire does not produce any field at the point of interest. Then use the Biot-Savart law on the other half.

5.11 Argue that the radial lines do not contribute. Note that the field due to the two arcs are in opposite directions to each other.

5.12 First find the field created by wire 1 at the location of wire 2. Then find the force that this field produces on wire 2.

5.13 Use Ampere's Law.

5.14 Use Ampere's Law.

5.15 Since the current density is not uniform, $I_{\text{in}} = \int JdA$.

6.1 The induced current is in the same direction as the electric field. Determine the direction of the induced field in the center of the loop, from the known electric field direction. Compare the induced field with the existing field.

6.2 Choose the Amperian loop to be a circle with radius r and going through the desired field point half way between the plates. Note that the current density between the plates is zero.

6.3 Use Kirchhoff's loop rule to write an equation in the current and the derivative of the current. Try a solution of the form $I(t) = a + be^{-\alpha t}$.

6.4 The RMS voltage of the source in the a standard outlet is 120 volts.

6.5 Follow the example in the text for an RC circuit.

6.6 Use a phasor diagram to draw Kirchhoff's loop rule, then find the frequency that minimizes the effective impedance of the RLC combination.

6.8 Use Faraday's law. Assume that the magnetic field decreases at a constant rate over the 20 ms that it goes from 1.6 T to zero, that is

$$dB/dt = (-1.6\text{T})/(20\text{ms}).$$

6.10 Since the field strength decreases as you move further from the wire you will need to do an integral in order to compute the magnetic flux.

6.11 Use Ampere's Law.

6.13 Consider that $Q = \int Idt$ and $I = V/R = \mathcal{E}/R$.

7.2 Start from $x = A \cos \phi$.

7.3 Take a look at the diagram of the oscillator that shows the phase angle at different points in the cycle. For the last part remember that $v = dx/dt$ and consider the quantity v/x .

7.4 Recall that the phase is $\phi = \omega t + \phi_0$ so that $\Delta\phi = \omega\Delta t$. Then consider by how much the phase must change in order for the oscillator to complete one cycle.

7.8 First compute the phase difference. Remember that $\phi_1 = -kr_1$ and $\phi_2 = -kr_2$. Next use the addition of two waves theorem.

7.9 The collection of points with the same Δr will form a continuous line, just like the collection of points that are all 5cm from a single point makes a circle or radius 5 cm.

7.10 Treat the two holes as two sources.

7.11 The phase of each path is now $-kr$ plus the reflection phase shift.

7.12 Find the distance from the lower speaker to the point P as a function of the distance d .

7.15 The path difference occurs in air.

7.16 Use the far field approximation to find the path difference.

7.18 Use the trig identities in the appendix.

7.19 There is a path difference, $d \sin \theta$, on both sides of the screen.

7.22 The air gap between the plates will be wedge shaped, because the thickness of the air gap increases as you move toward the wire, there will be an increasing phase difference between the two reflected beams. This leads to the fringes.

7.24 As the slit gets narrower the angle of the first minima increases. There is a limit to the increase.

7.26 The distance from the central maximum to the first order maximum is the same as it would be for a double slit with the same distance between the two slits as there is between successive lines in the diffraction grating.

8.1 Use similar triangles and note that the sun is about three times bigger than the person in the image.

8.2 Use geometry to show that

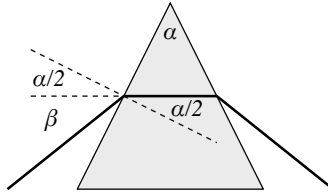

Then use Snells law.

8.3 Each straight line segment that crosses the optical axis, creates two similar triangles, one above the axis and one below the axis. Use the properties of similar triangles to get an equation for each of these pairs.

8.6 Use the thin lens equation to find under what conditions the image distance is negative.

8.8 Use the thin lens equation.

8.9 Start with the magnification equation.

B**Index**

- † Energy Density of an Electric Field, 48
- † Addition of Two Waves, 147
- † Ampere's Law - Time Varying, 120
- † Ampere's Law, 102
- † Biot-Savart Law, 97
- † Circular Trajectories, 84
- † Conductor in Equilibrium: Charge, 43
- † Conductor in Equilibrium: Field, 43
- † Conductor in Equilibrium: Potential, 44
- † Conductor in Equilibrium: Surface Field, 44
- † Coulomb's Law in Vector Form, 8
- † Coulomb's Law, 8
- † Effective Capacitance, 65
- † Effective Resistance, 64
- † Electric Charge, 4
- † Electric Field due to a Point Charge, 15
- † Electric Field from the Electric Potential, 40
- † Electric Potential of a Point Charge, 48
- † Electrical Power, 61
- † Electromagnetic Waves and Light, 139
- † Energy Stored in a Capacitor, 47
- † Faraday's Law (alternate form), 117
- † Faraday's Law, 116
- † Force Currents, 105
- † Force on a Current in a Uniform Field, 82
- † Gauss's Law, 20
- † Impedance: Capacitor, 125
- † Impedance: Inductor, 124
- † Interference of Two Sources, 150
- † Kirchhoff's Junction Rule, 61
- † Kirchhoff's Loop Rule, 62
- † Law of reflection, 162
- † Lenz's Law, 119
- † Magnetic Force on a Current, 82
- † Magnetic Force, 81
- † Magnification Equations, 169

† Ohm's Law: Resistance, 60
† Ohm's Law: Resistivity, 59
† Reflection Phase Shift, 154
† Short Wavelength Limit, 161
† Single Slit Diffraction, 155
† Snell's Law, 163
† Superposition Theorem, 15
† Thin Lens Equations, 168
† Two Types of Charge, 4
† Wave due to a Sinusoidal Point Source, 142
† Wavelength in a Medium, 154
† Work by Magnetic Force, 84
alternating current, 122
capacitance, 46
conductivity, 59
conductor, 7
converging lens, 166
current density, 58
current, 58
cyclotron, 85
direct current, 122
displacement current, 120
Diverging Lens, 171
electric field, 10
electric field, 11
electric flux, 20
electric potential, 37
electromagnet, 97
electromagnetic, 139
electromotive force, 116
elements, 57
EMF, 116
equipotential, 41
Farad, 46
field lines, 14
focal length, 166
focal plane, 167
focal point, 166
focus, 166
frequency, 143
gain, 128
gradient, 40

ground, 38
Hall Effect, 87
Henry, 120
in parallel, 62
in series, 62
in-phase, 147
index of refraction, 153
inductance, 120
infrared, 145
Lorentz Force, 85
magnetic flux, 117
n-type, 88
non-ohmic, 59
ohm, 60
ohmic, 59
optical axis, 166
out-of-phase, 148
p-type, 88
parameterization, 39
parameterize, 98
period, 143
phase, 139
phasor, 125
principle focus, 166
principle rays, 168
real image, 168
resistance, 60
resistivity, 59
Resistor, 59
resonance, 129
scalar field, 16
steady state, 115
Tesla, 82
ultraviolet, 145
uniform, 16
vector field, 16
velocity selector, 86
wavelength, 142
wiring diagram, 57

C

Useful Mathematics

§ C.1 Trigonometry

$$\cos(a + b) = \cos a \cos b - \sin a \sin b$$

$$\sin(a + b) = \sin a \cos b + \cos a \sin b$$

$$\cos a + \cos b = 2 \cos \frac{b-a}{2} \cos \frac{b+a}{2}$$

$$\cos a - \cos b = 2 \sin \frac{b-a}{2} \sin \frac{b+a}{2}$$

$$\sin a + \sin b = 2 \cos \frac{b-a}{2} \sin \frac{b+a}{2}$$

§ C.2 Fundamental Derivatives and Integrals

Basic Facts

$$\frac{d}{dx}[x^p] = px^{p-1}$$

$$\int x^p dx = \frac{x^{p+1}}{p+1}$$

$$\frac{d}{dx}[e^{ax}] = ae^{ax}$$

$$\int e^{ax} dx = \frac{e^{ax}}{a}$$

$$\frac{d}{dx}[\ln(x)] = \frac{1}{x}$$

$$\int \frac{1}{x} dx = \ln(x)$$

$$\frac{d}{dx}[\sin(kx)] = k \cos(kx)$$

$$\int \cos(kx) dx = \frac{\sin(kx)}{k}$$

$$\frac{d}{dx}[\cos(kx)] = -k \sin(kx)$$

$$\int \sin(kx) dx = -\frac{\cos(kx)}{k}$$

Divide and Conquer Rules

Sum Rule:

$$f(x) = a g(x) + b h(x) \longrightarrow \frac{df}{dx} = a \frac{dg}{dx} + b \frac{dh}{dx}$$

Example: $\frac{d}{dx}[3x^2 + 4x^3] = 3 \frac{d}{dx}[x^2] + 4 \frac{d}{dx}[x^3] = 6x + 12x^2.$

Product Rule:

$$f(x) = g(x) h(x) \longrightarrow \frac{df}{dx} = g(x) \frac{dh}{dx} + \frac{dg}{dx} h(x)$$

Example: $\frac{d}{dx}[x^2 \sin(x)] = x^2 \frac{d}{dx}[\sin(x)] + \frac{d}{dx}[x^2] \sin(x) = x^2 \cos(x) + 2x \sin(x).$

Chain Rule:

$$f(x) = g(h(x)) \longrightarrow \frac{df}{dx} = \frac{dg}{dh} \frac{dh}{dx}$$

Example: $\frac{d}{dx}[\sin(3x^2)] = \frac{d}{d[3x^2]}[\sin(3x^2)] \frac{d}{dx}[3x^2] = \cos(3x^2)6x$

The Fundamental Theorem of Calculus

Recall that the distance traveled between time t_1 and time t_2 is equal to the area under the v versus t graph between these times.

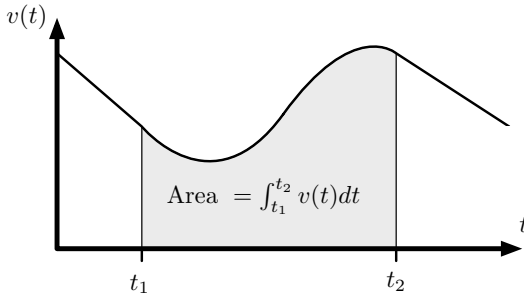

But the distance traveled is also $x(t_2) - x(t_1)$. So we find that

$$\int_{t_1}^{t_2} v(t) dt = x(t_2) - x(t_1)$$

This works for any pair of functions where one is the derivative of the other. So in general

$$\mathbf{IF} \quad f(t) = \frac{dg}{dt} \quad \mathbf{THEN} \quad \int_{t_1}^{t_2} f(t) dt = g(t_2) - g(t_1)$$

§ C.3 Power Series Expansions

$$\frac{1}{1-x} = \sum_{n=0}^{\infty} x^n = 1 + x + x^2 + x^3 + x^4 \dots$$

$$\frac{1}{1-x} = \sum_{n=0}^N x^n = \sum_{n=0}^{\infty} x^n - \sum_{n=N+1}^{\infty} x^n$$

$$\sin(x) = \sum_{n=0}^{\infty} \frac{(-1)^n}{(2n+1)!} x^{2n+1} = x - \frac{1}{6}x^3 + \dots$$

$$\cos(x) = \sum_{n=0}^{\infty} \frac{(-1)^n}{(2n)!} x^{2n} = 1 - \frac{1}{2}x^2 + \dots$$

$$e^x = \sum_{n=0}^{\infty} \frac{1}{n!} x^n = 1 + x + \frac{1}{2}x^2 + \frac{1}{6}x^3 + \dots$$

$$(1+x)^N = \sum_{n=0}^N \frac{N!}{n!(N-n)!} x^n = 1 + Nx + \frac{N!}{2!(N-2)!} x^2 + \dots$$

D

Physical Constants and Data

§ D.1 Astronomical Data

Average orbital radius of the Earth about the Sun	$1.50 \times 10^8 \text{ km}$
Average orbital radius of the Moon about the Earth	$3.84 \times 10^5 \text{ km}$
Radius of the Earth (at the equator)	$6.37 \times 10^3 \text{ km}$
Radius of the Sun	$6.96 \times 10^5 \text{ km}$
Radius of the Moon	$1.74 \times 10^3 \text{ km}$
Orbital period of the Earth about the Sun	365.257 days
Orbital period of the Moon about the Earth	27.322 days

§ D.2 Index of Refraction

(at $\lambda=589.3 \text{ nm}$, from wikipedia.org)

Material	Index
Vacuum	1 (exactly)
Helium	1.000036
Air at STP	1.0002926
carbon dioxide	1.00045
water ice	1.31
liquid water (20C)	1.333
ethanol	1.36
glycerine	1.47
polycarbonate	1.59
glass (typical)	1.5 to 1.9
cubic zirconia	2.2
diamond	2.4
moissanite	2.7
gallium phosphide	3.5
gallium arsenide	3.9
silicon	4.0

§ D.3 Approximate Electrical Conductivity

(from wikipedia.org)

Material	$\Omega^{-1} \cdot \text{m}^{-1}$
Silver	63.0×10^6
Copper	59.6×10^6
Gold	45.0×10^6
Aluminium	37.8×10^6
Brass	20.0×10^6
Iron	10.0×10^6
Bronze	7.0×10^6
Lead	4.8×10^6
Stainless Steel	1.4×10^6
Seawater	5.0×10^0
Drinking water	5.0×10^{-3}
Deionized water	5.5×10^{-6}
Glass	$\sim 10^{-12}$
Rubber	$\sim 10^{-13}$

§ D.4 Fundamental Constants

speed of light	c	$2.99792458 \times 10^8 \frac{\text{m}}{\text{s}}$	(exact)
Planck constant	h	$6.6260755(40) \times 10^{-34} \text{J} \cdot \text{s}$	
	hc	$1239.8424(93) \text{eV} \cdot \text{nm}$	
		$1240 \text{eV} \cdot \text{nm}$	
	\hbar	$1.05457266(63) \times 10^{-34} \text{J} \cdot \text{s}$	
	$\hbar c$	$197.327053(59) \text{eV} \cdot \text{nm}$	
fundamental charge	e	$1.60217733(49) \times 10^{-19} \text{C}$	
mass of electron	m_e	$9.1093897(54) \times 10^{-31} \text{kg}$	
		$0.51099906(15) \text{MeV}/c^2$	
mass of proton	m_p	$1.672631(10) \times 10^{-27} \text{kg}$	
		$938.27231(28) \text{MeV}/c^2$	
Boltzman constant	k	$1.380658(12) \times 10^{-23} \text{J/K}$	
		$8.617385(73) \times 10^{-5} \text{eV/K}$	
Avogadro number	N_A	$6.0221367(36) \times 10^{23}$	
permeability of free space	μ_0	$4\pi \times 10^{-7} \text{N/A}^2$	(exact)
permittivity of free space	ϵ_0	$1/(\mu_0 c^2)$	(exact)
		$8.854187817 \times 10^{-12} \text{C}^2/\text{N} \cdot \text{m}^2$	
gravitational constant	$\frac{1}{4\pi\epsilon_0}$	$8.99 \times 10^9 \text{N} \cdot \text{m}^2/\text{C}^2$	
	G	$6.67259(85) \times 10^{-11} \text{m}^2/\text{kg} \cdot \text{s}$	

§ D.5 Unit Conversions

1 m	3.28 ft
1.6 km	1 mile
1 mile	5280 ft
1 hp	746 W
1 liter	$1 \times 10^{-3} \text{m}^3$
1 gallon	3.79 liters
1 atm	$1.013 \times 10^5 \text{Pa}$
1 J	0.239 cal
1 kcal	4186 J

§ D.6 Unit Prefixes

f	femto	10^{-15}
p	pico	10^{-12}
n	nano	10^{-9}
μ	micro	10^{-6}
m	milli	10^{-3}
k	kilo	10^3
M	mega	10^6
G	giga	10^9
T	tera	10^{12}